

BG

ДЕКЛАРАЦИЯ ЗА ЕКСПЛОАТАЦИОННИ ПОКАЗАТЕЛИ

в съответствие с Приложение III на Регламент (ЕС) № 305/2011 (Регламент за строителните продукти)

 Самонарезни винтове S-MS Z, S-MS C на Хилти
 № Hilti-SF-DoP-003

- 1. Уникален идентификационен код на типа на продукта:** Самонарезни винтове S-MS Z, S-MS C на Хилти
- 2. Тип, партиден или сериен номер или друг елемент, който позволява да се идентифицира строителният продукт съгласно изискванията на член 11, параграф 4:** Типът и номерът на партидата са показани на опаковката
- 3. Предвидена употреба или употреби на строителния продукт в съответствие с приложимата хармонизирана техническа спецификация, както е предвидено от производителя:**

Настройван тип и употреба	Самонарезни монтажни винтове за метални елементи и листове
Обхванати размери на продукта	Диаметър на винтовете 4,8 mm
Материал на основата и закрепван материал	Стомана съгласно EN 10346 Алуминиева сплав съгласно EN 485 / EN 573
Материал на крепежните елементи	Галванизирана или покрита, циментирана въглеродна стомана съгласно EN 10084
Натоварване	Статично и квазистатично (ветрово натоварване)

- 4. Име, регистрирано търговско наименование или регистрирана търговска марка и адрес за контакт на производителя съгласно изискванията на член 11, параграф 5:** Hilti Aktiengesellschaft, Business Unit Direct Fastening, 9494 Schaan, Княжество Лихтенщайн
- 5. Когато е приложимо, име и адрес за контакт на упълномощения представител, чието пълномощие включва задачите, посочени в член 12, параграф 2:** не е приложимо
- 6. Система или системи за оценяване и проверка на постоянството на експлоатационните показатели на строителния продукт, както са изложени в приложение V:** Система 2+
- 7. В случай на декларация за експлоатационни показатели относно строителен продукт, обхванат от хармонизиран стандарт:** не е приложимо
- 8. В случай на декларация за експлоатационни показатели във връзка със строителен продукт, за който има издадена Европейска техническа оценка:**
Издадено на базата на EAD 330046-01-0602 ETA-10/0182. Нотифицираният орган MPA-Karlsruhe 0769 изпълни задачи като трета страна по система 2+ и издаде сертификата за съответствие на фабричния производствен контрол.

9. Декларирани експлоатационни показатели:

Съществена характеристика	Експлоатационни показатели	Хармонизирана техническа спецификация
Характеристична якост на опън $N_{R,k}$	Приложение 1 - 6 ETA-10/0182 (Приложение 4 - 9)	ETA-10/0182 EAD 330046-01-0602
Характеристична якост на срязване $V_{R,k}$		
Видове връзки		
Граници на приложение		
Реакция на огън	A1	

- 10. Експлоатационните показатели на продукта, посочен в точки 1 и 2, са в съответствие с декларираните експлоатационни показатели в точка 9. Настоящата декларация за експлоатационни показатели се издава под единствената отговорност на производителя, посочен в точка 4.**

Подписано за и от името на производителя от:

Lars Taenzer

Ръководител на бизнес филиал "Директно закрепване"

Pierre Hohmeier

Ръководител по качеството "Закрепване с винтове"

Hilti Aktiengesellschaft, Schaan, 03.05.2019 г.

Annex 1:
ETA-10/0182, Annex 4

Material:

Fastener: carbon steel, case hardened and galvanized or coated

Washer: none

Component I: S280GD, S320GD, S350GD - EN 10346

Component II: S280GD, S320GD, S350GD - EN 10346

Drilling capacity: $\Sigma t_i \leq 2,50$ mm

Timber substructures:
no performance determined

t [mm]	t _i [mm]								
	0,50	0,55	0,63	0,75	0,88	1,00	1,13	1,25	
V _{0,x} [kN]	0,50	1,29	1,37	1,51	1,71	1,71	1,71	1,71	1,71
	0,55	1,29	1,54	1,65	1,82	1,82	1,82	1,82	2,05
	0,63	1,29	1,54	1,80	2,00	2,00	2,00	2,00	2,59
	0,75	1,29	1,54	1,80	2,27	2,27	2,27	2,84	3,40
	0,88	1,29	1,54	1,80	2,27	2,96	2,96	2,96	3,40
	1,00	1,29	1,54	1,80	2,27	2,96	3,64	3,64	3,64
	1,13	1,29	1,54	1,80	2,27	2,96	3,64	3,87	3,87
	1,25	1,29	1,54	1,80	2,27	2,96	3,64	3,87	4,10
	1,50	1,29	1,54	1,80	2,27	2,96	3,64	—	—
	1,75	1,29	1,54	1,80	2,27	—	—	—	—
	2,00	1,29	—	—	—	—	—	—	—
N _{0,x} [kN]	0,50	0,76	0,87	1,04	1,29	1,56	1,82	1,93	1,93
	0,55	0,76	0,87	1,04	1,29	1,56	1,82	2,09	2,25
	0,63	0,76	0,87	1,04	1,29	1,56	1,82	2,09	2,34
	0,75	0,76	0,87	1,04	1,29	1,56	1,82	2,09	2,34
	0,88	0,76	0,87	1,04	1,29	1,56	1,82	2,09	2,34
	1,00	0,76	0,87	1,04	1,29	1,56	1,82	2,09	2,34
	1,13	0,76	0,87	1,04	1,29	1,56	1,82	2,09	2,34
	1,25	0,76	0,87	1,04	1,29	1,56	1,82	2,09	2,34
	1,50	0,76	0,87	1,04	1,29	1,56	1,82	—	—
	1,75	0,76	0,87	1,04	1,29	—	—	—	—
	2,00	0,76	—	—	—	—	—	—	—
M _{0,perm} [Nm]									

No additional regulations.

Self piercing screw

Hilti S-MS 01 Z 4,8 x L
Hilti S-MS 01 C 4,8 x L
with hexagon head

Annex 4

Annex 2:
ETA-10/0182, Annex 5

	<p>Material:</p> <p>Fastener: carbon steel, case hardened and galvanized or coated</p> <p>Washer: carbon steel, galvanized or coated stainless Steel (1.4301) - EN 10088</p> <p>Component I: S280GD, S320GD, S350GD - EN 10346</p> <p>Component II: S280GD, S320GD, S350GD - EN 10346</p>																																																																																																																																																																																																																																																																																																																																													
	<p>Drilling capacity: $\Sigma t_i \leq 2,50$ mm</p>																																																																																																																																																																																																																																																																																																																																													
<p>Timber substructures: no performance determined</p>																																																																																																																																																																																																																																																																																																																																														
<table border="1"> <thead> <tr> <th rowspan="2"></th> <th rowspan="2">t_i [mm]</th> <th colspan="12">t_i [mm]</th> </tr> <tr> <th>0,40</th><th>0,50</th><th>0,55</th><th>0,63</th><th>0,75</th><th>0,88</th><th>1,00</th><th>1,25</th> <th>0,40</th><th>0,50</th><th>0,55</th><th>0,63</th><th>0,75</th><th>0,88</th><th>1,00</th><th>1,25</th> </tr> </thead> <tbody> <tr> <td rowspan="8">V_{Rk} [kN]</td> <td>0,40</td><td>0,81</td><td>0,87</td><td>0,90</td><td>0,95</td><td>1,03</td><td>1,03</td><td>1,03</td><td>1,03</td><td>1,03</td><td>1,03</td><td>1,03</td><td>1,03</td><td>1,03</td><td>1,03</td><td>1,03</td><td>1,03</td> </tr> <tr> <td>0,50</td><td>0,81</td><td>1,01</td><td>1,01</td><td>1,02</td><td>1,03</td><td>1,03</td><td>1,03</td><td>1,03</td><td>1,03</td><td>1,03</td><td>1,03</td><td>1,03</td><td>1,03</td><td>1,03</td><td>1,03</td><td>1,03</td> </tr> <tr> <td>0,55</td><td>0,81</td><td>1,01</td><td>1,26</td><td>1,26</td><td>1,26</td><td>1,26</td><td>1,26</td><td>1,26</td><td>1,26</td><td>1,26</td><td>1,26</td><td>1,26</td><td>1,26</td><td>1,26</td><td>1,26</td><td>1,26</td> </tr> <tr> <td>0,63</td><td>0,81</td><td>1,01</td><td>1,26</td><td>1,66</td><td>1,66</td><td>1,66</td><td>1,66</td><td>1,66</td><td>1,66</td><td>1,66</td><td>1,66</td><td>1,66</td><td>1,66</td><td>1,66</td><td>1,66</td><td>1,66</td> </tr> <tr> <td>0,75</td><td>0,81</td><td>1,01</td><td>1,26</td><td>1,66</td><td>2,26</td><td>2,26</td><td>2,26</td><td>2,26</td><td>2,26</td><td>2,26</td><td>2,26</td><td>2,26</td><td>2,26</td><td>2,26</td><td>2,26</td><td>2,26</td> </tr> <tr> <td>0,88</td><td>0,81</td><td>1,01</td><td>1,26</td><td>1,66</td><td>2,26</td><td>2,77</td><td>2,77</td><td>2,77</td><td>2,77</td><td>2,77</td><td>2,77</td><td>2,77</td><td>2,77</td><td>2,77</td><td>2,77</td><td>2,77</td> </tr> <tr> <td>1,00</td><td>0,81</td><td>1,01</td><td>1,26</td><td>1,66</td><td>2,26</td><td>2,77</td><td>3,24</td><td>3,24</td><td>3,24</td><td>3,24</td><td>3,24</td><td>3,24</td><td>3,24</td><td>3,24</td><td>3,24</td><td>3,24</td> </tr> <tr> <td>1,25</td><td>0,81</td><td>1,01</td><td>1,26</td><td>1,66</td><td>2,26</td><td>2,77</td><td>3,24</td><td>4,24</td><td>4,24</td><td>4,24</td><td>4,24</td><td>4,24</td><td>4,24</td><td>4,24</td><td>4,24</td><td>4,24</td> </tr> <tr> <td rowspan="8">N_{Rk} [kN]</td> <td>0,40</td><td>0,46</td><td>0,76</td><td>0,88</td><td>1,03</td><td>1,27</td><td>1,43</td><td>1,43</td><td>1,43</td><td>1,43</td><td>1,43</td><td>1,43</td><td>1,43</td><td>1,43</td><td>1,43</td><td>1,43</td><td>1,43</td> </tr> <tr> <td>0,50</td><td>0,46</td><td>0,76</td><td>0,88</td><td>1,03</td><td>1,27</td><td>1,60</td><td>1,80</td><td>1,80</td><td>1,80</td><td>1,80</td><td>1,80</td><td>1,80</td><td>1,80</td><td>1,80</td><td>1,80</td><td>1,80</td> </tr> <tr> <td>0,55</td><td>0,46</td><td>0,76</td><td>0,88</td><td>1,03</td><td>1,27</td><td>1,60</td><td>1,90</td><td>1,90</td><td>1,90</td><td>1,90</td><td>1,90</td><td>1,90</td><td>1,90</td><td>1,90</td><td>1,90</td><td>1,90</td> </tr> <tr> <td>0,63</td><td>0,46</td><td>0,76</td><td>0,88</td><td>1,03</td><td>1,27</td><td>1,60</td><td>1,90</td><td>2,34</td><td>2,34</td><td>2,34</td><td>2,34</td><td>2,34</td><td>2,34</td><td>2,34</td><td>2,34</td><td>2,34</td> </tr> <tr> <td>0,75</td><td>0,46</td><td>0,76</td><td>0,88</td><td>1,03</td><td>1,27</td><td>1,60</td><td>1,90</td><td>2,49</td><td>2,49</td><td>2,49</td><td>2,49</td><td>2,49</td><td>2,49</td><td>2,49</td><td>2,49</td><td>2,49</td> </tr> <tr> <td>0,88</td><td>0,46</td><td>0,76</td><td>0,88</td><td>1,03</td><td>1,27</td><td>1,60</td><td>1,90</td><td>2,49</td><td>2,49</td><td>2,49</td><td>2,49</td><td>2,49</td><td>2,49</td><td>2,49</td><td>2,49</td><td>2,49</td> </tr> <tr> <td>1,00</td><td>0,46</td><td>0,76</td><td>0,88</td><td>1,03</td><td>1,27</td><td>1,60</td><td>1,90</td><td>2,49</td><td>2,49</td><td>2,49</td><td>2,49</td><td>2,49</td><td>2,49</td><td>2,49</td><td>2,49</td><td>2,49</td> </tr> <tr> <td>1,25</td><td>0,46</td><td>0,76</td><td>0,88</td><td>1,03</td><td>1,27</td><td>1,60</td><td>1,90</td><td>2,49</td><td>2,49</td><td>2,49</td><td>2,49</td><td>2,49</td><td>2,49</td><td>2,49</td><td>2,49</td><td>2,49</td> </tr> <tr> <td>M_{Rk} [Nm]</td> <td colspan="17"></td> </tr> </tbody> </table>														t_i [mm]	t_i [mm]												0,40	0,50	0,55	0,63	0,75	0,88	1,00	1,25	0,40	0,50	0,55	0,63	0,75	0,88	1,00	1,25	V_{Rk} [kN]	0,40	0,81	0,87	0,90	0,95	1,03	1,03	1,03	1,03	1,03	1,03	1,03	1,03	1,03	1,03	1,03	1,03	0,50	0,81	1,01	1,01	1,02	1,03	1,03	1,03	1,03	1,03	1,03	1,03	1,03	1,03	1,03	1,03	1,03	0,55	0,81	1,01	1,26	1,26	1,26	1,26	1,26	1,26	1,26	1,26	1,26	1,26	1,26	1,26	1,26	1,26	0,63	0,81	1,01	1,26	1,66	1,66	1,66	1,66	1,66	1,66	1,66	1,66	1,66	1,66	1,66	1,66	1,66	0,75	0,81	1,01	1,26	1,66	2,26	2,26	2,26	2,26	2,26	2,26	2,26	2,26	2,26	2,26	2,26	2,26	0,88	0,81	1,01	1,26	1,66	2,26	2,77	2,77	2,77	2,77	2,77	2,77	2,77	2,77	2,77	2,77	2,77	1,00	0,81	1,01	1,26	1,66	2,26	2,77	3,24	3,24	3,24	3,24	3,24	3,24	3,24	3,24	3,24	3,24	1,25	0,81	1,01	1,26	1,66	2,26	2,77	3,24	4,24	4,24	4,24	4,24	4,24	4,24	4,24	4,24	4,24	N_{Rk} [kN]	0,40	0,46	0,76	0,88	1,03	1,27	1,43	1,43	1,43	1,43	1,43	1,43	1,43	1,43	1,43	1,43	1,43	0,50	0,46	0,76	0,88	1,03	1,27	1,60	1,80	1,80	1,80	1,80	1,80	1,80	1,80	1,80	1,80	1,80	0,55	0,46	0,76	0,88	1,03	1,27	1,60	1,90	1,90	1,90	1,90	1,90	1,90	1,90	1,90	1,90	1,90	0,63	0,46	0,76	0,88	1,03	1,27	1,60	1,90	2,34	2,34	2,34	2,34	2,34	2,34	2,34	2,34	2,34	0,75	0,46	0,76	0,88	1,03	1,27	1,60	1,90	2,49	2,49	2,49	2,49	2,49	2,49	2,49	2,49	2,49	0,88	0,46	0,76	0,88	1,03	1,27	1,60	1,90	2,49	2,49	2,49	2,49	2,49	2,49	2,49	2,49	2,49	1,00	0,46	0,76	0,88	1,03	1,27	1,60	1,90	2,49	2,49	2,49	2,49	2,49	2,49	2,49	2,49	2,49	1,25	0,46	0,76	0,88	1,03	1,27	1,60	1,90	2,49	2,49	2,49	2,49	2,49	2,49	2,49	2,49	2,49	M_{Rk} [Nm]																	
	t_i [mm]	t_i [mm]																																																																																																																																																																																																																																																																																																																																												
		0,40	0,50	0,55	0,63	0,75	0,88	1,00	1,25	0,40	0,50	0,55	0,63	0,75	0,88	1,00	1,25																																																																																																																																																																																																																																																																																																																													
V_{Rk} [kN]	0,40	0,81	0,87	0,90	0,95	1,03	1,03	1,03	1,03	1,03	1,03	1,03	1,03	1,03	1,03	1,03	1,03																																																																																																																																																																																																																																																																																																																													
	0,50	0,81	1,01	1,01	1,02	1,03	1,03	1,03	1,03	1,03	1,03	1,03	1,03	1,03	1,03	1,03	1,03																																																																																																																																																																																																																																																																																																																													
	0,55	0,81	1,01	1,26	1,26	1,26	1,26	1,26	1,26	1,26	1,26	1,26	1,26	1,26	1,26	1,26	1,26																																																																																																																																																																																																																																																																																																																													
	0,63	0,81	1,01	1,26	1,66	1,66	1,66	1,66	1,66	1,66	1,66	1,66	1,66	1,66	1,66	1,66	1,66																																																																																																																																																																																																																																																																																																																													
	0,75	0,81	1,01	1,26	1,66	2,26	2,26	2,26	2,26	2,26	2,26	2,26	2,26	2,26	2,26	2,26	2,26																																																																																																																																																																																																																																																																																																																													
	0,88	0,81	1,01	1,26	1,66	2,26	2,77	2,77	2,77	2,77	2,77	2,77	2,77	2,77	2,77	2,77	2,77																																																																																																																																																																																																																																																																																																																													
	1,00	0,81	1,01	1,26	1,66	2,26	2,77	3,24	3,24	3,24	3,24	3,24	3,24	3,24	3,24	3,24	3,24																																																																																																																																																																																																																																																																																																																													
	1,25	0,81	1,01	1,26	1,66	2,26	2,77	3,24	4,24	4,24	4,24	4,24	4,24	4,24	4,24	4,24	4,24																																																																																																																																																																																																																																																																																																																													
N_{Rk} [kN]	0,40	0,46	0,76	0,88	1,03	1,27	1,43	1,43	1,43	1,43	1,43	1,43	1,43	1,43	1,43	1,43	1,43																																																																																																																																																																																																																																																																																																																													
	0,50	0,46	0,76	0,88	1,03	1,27	1,60	1,80	1,80	1,80	1,80	1,80	1,80	1,80	1,80	1,80	1,80																																																																																																																																																																																																																																																																																																																													
	0,55	0,46	0,76	0,88	1,03	1,27	1,60	1,90	1,90	1,90	1,90	1,90	1,90	1,90	1,90	1,90	1,90																																																																																																																																																																																																																																																																																																																													
	0,63	0,46	0,76	0,88	1,03	1,27	1,60	1,90	2,34	2,34	2,34	2,34	2,34	2,34	2,34	2,34	2,34																																																																																																																																																																																																																																																																																																																													
	0,75	0,46	0,76	0,88	1,03	1,27	1,60	1,90	2,49	2,49	2,49	2,49	2,49	2,49	2,49	2,49	2,49																																																																																																																																																																																																																																																																																																																													
	0,88	0,46	0,76	0,88	1,03	1,27	1,60	1,90	2,49	2,49	2,49	2,49	2,49	2,49	2,49	2,49	2,49																																																																																																																																																																																																																																																																																																																													
	1,00	0,46	0,76	0,88	1,03	1,27	1,60	1,90	2,49	2,49	2,49	2,49	2,49	2,49	2,49	2,49	2,49																																																																																																																																																																																																																																																																																																																													
	1,25	0,46	0,76	0,88	1,03	1,27	1,60	1,90	2,49	2,49	2,49	2,49	2,49	2,49	2,49	2,49	2,49																																																																																																																																																																																																																																																																																																																													
M_{Rk} [Nm]																																																																																																																																																																																																																																																																																																																																														
<p>If both components I and II are made of S320GD or S350GD the grey highlighted values may be increased by 8,0%.</p>																																																																																																																																																																																																																																																																																																																																														
<p>Self piercing screw</p> <p>Hilti S-MS 41 Z 4,8 x L Hilti S-MS 41 C 4,8 x L Hilti S-MS 51 Z 4,8 x L Hilti S-MS 51 C 4,8 x L with hexagon head and sealing washer $\geq \varnothing 14$ mm</p>											<p>Annex 5</p>																																																																																																																																																																																																																																																																																																																																			

Annex 3:
ETA-10/0182, Annex 6

Material:

Fastener: carbon steel, case hardened and galvanized or coated

Washer: carbon steel, galvanized or coated
stainless Steel (1.4301) - EN 10088

Component I: aluminium alloy with $R_{m,min} = 215 \text{ N/mm}^2$ - EN 573

Component II: aluminium alloy with $R_{m,min} = 215 \text{ N/mm}^2$ - EN 573

Drilling capacity: $\Sigma t_i \leq 2,50 \text{ mm}$

Timber substructures:
no performance determined

t [mm]	t _i [mm]						
	0,50	0,60	0,70	0,80	1,00	1,20	
V _{rel,k} [kN]	0,50	0,71	0,71	0,71	0,71	0,71	0,71
	0,60	0,71	0,92	0,92	0,92	0,92	0,92
	0,70	0,71	0,92	1,14	1,14	1,14	1,14
	0,80	0,71	0,92	1,14	1,35	1,35	1,35
	1,00	0,71	0,92	1,14	1,35	1,88	1,88
	1,20	0,71	0,92	1,14	1,35	1,88	2,28
N _{s,k} [kN]	0,50	0,35	0,49	0,52	0,52	0,52	0,52
	0,60	0,35	0,49	0,63	0,63	0,63	0,63
	0,70	0,35	0,49	0,63	0,73	0,73	0,73
	0,80	0,35	0,49	0,63	0,77	0,84	0,84
	1,00	0,35	0,49	0,63	0,77	1,00	1,05
	1,20	0,35	0,49	0,63	0,77	1,00	1,26
N _{R,ilk} [kN]	0,35	0,49	0,63	0,77	1,00	1,29	
M _{torq,m} [Nm]							

The pull-through-capacities of the grey highlighted values N_{s,k} have been determined according to EN 1999-1-4:2007 section 8.3.3.1 by calculation. This values N_{s,k} may be increased by 6,9% when using the type „S-MS 5x“.

Self piercing screw	Annex 6
Hilti S-MS 41 Z 4,8 x L Hilti S-MS 41 C 4,8 x L Hilti S-MS 51 Z 4,8 x L Hilti S-MS 51 C 4,8 x L with hexagon head and sealing washer ≥ Ø14 mm	

Annex 4:
ETA-10/0182, Annex 7

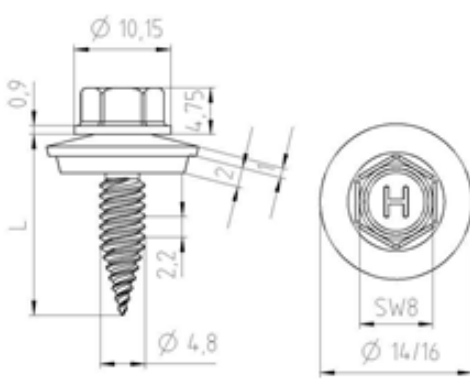

Material:

Fastener: carbon steel, case hardened and galvanized or coated

Washer: carbon steel, galvanized or coated stainless Steel (1.4301) - EN 10088

Component I: aluminium alloy with $R_{m,min} = 165 \text{ N/mm}^2$ - EN 573

Component II: aluminium alloy with $R_{m,min} = 165 \text{ N/mm}^2$ - EN 573

Drilling capacity: $\Sigma t_i \leq 2,50 \text{ mm}$

Timber substructures:
no performance determined

t [mm]	t _i [mm]						
	0,50	0,60	0,70	0,80	1,00	1,20	
V _{rel} [kN]	0,50	0,55	0,55	0,55	0,55	0,55	0,55
	0,60	0,55	0,71	0,71	0,71	0,71	0,71
	0,70	0,55	0,71	0,88	0,88	0,88	0,88
	0,80	0,55	0,71	0,88	1,04	1,04	1,04
	1,00	0,55	0,71	0,88	1,04	1,44	1,44
	1,20	0,55	0,71	0,88	1,04	1,44	1,83
N _{2,x} [kN]	0,50	0,27	0,38	0,40	0,40	0,40	0,40
	0,60	0,27	0,38	0,48	0,48	0,48	0,48
	0,70	0,27	0,38	0,48	0,56	0,56	0,56
	0,80	0,27	0,38	0,48	0,59	0,64	0,64
	1,00	0,27	0,38	0,48	0,59	0,76	0,80
	1,20	0,27	0,38	0,48	0,59	0,76	0,98
N _{2,lik} [kN]	0,27	0,38	0,48	0,59	0,76	1,03	
M _{1,10m} [Nm]							

The pull-through-capacities of the grey highlighted values $N_{2,x}$ have been determined according to EN 1999-1-4:2007 section 8.3.3.1 by calculation. This values $N_{2,x}$ may be increased by 6,9% when using the type „S-MS 5x“.

Self piercing screw	Annex 7
Hilti S-MS 41 Z 4,8 x L Hilti S-MS 41 C 4,8 x L Hilti S-MS 51 Z 4,8 x L Hilti S-MS 51 C 4,8 x L with hexagon head and sealing washer $\geq \varnothing 14 \text{ mm}$	

Annex 5:
ETA-10/0182, Annex 8

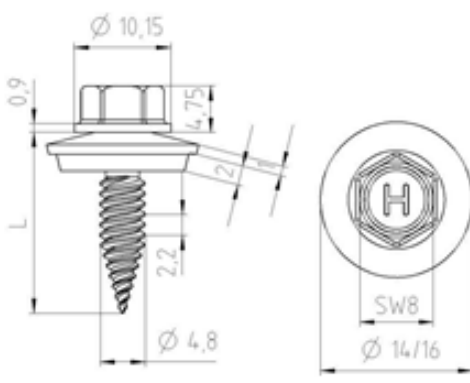

Material:

Fastener: carbon steel, case hardened and galvanized or coated

Washer: carbon steel, galvanized or coated
stainless Steel (1.4301) - EN 10088

Component I: aluminium alloy with $R_{m,min} = 215 \text{ N/mm}^2$ - EN 573

Component II: S280GD, S320GD, S350GD - EN 10346

Drilling capacity: $\Sigma t_i \leq 2,50 \text{ mm}$

Timber substructures:
no performance determined

t [mm]	t _i [mm]							
	0,50	0,55	0,63	0,75	0,88	1,00	1,25	
V _{FeK} [kN]	0,50	0,71	0,71	0,71	0,71	0,71	0,71	0,71
	0,60	0,71	0,71	0,92	0,92	0,92	0,92	0,92
	0,70	0,71	0,71	0,92	1,14	1,14	1,14	1,14
	0,80	0,71	0,71	0,92	1,14	1,35	1,35	1,35
	1,00	0,71	0,71	0,92	1,14	1,35	1,88	1,88
	1,20	0,71	0,71	0,92	1,14	1,35	1,88	2,28
N _{2,x} [kN]	0,50	0,52	0,52	0,52	0,52	0,52	0,52	0,52
	0,60	0,63	0,63	0,63	0,63	0,63	0,63	0,63
	0,70	0,73	0,73	0,73	0,73	0,73	0,73	0,73
	0,80	0,76	0,84	0,84	0,84	0,84	0,84	0,84
	1,00	0,76	0,87	1,04	1,05	1,05	1,05	1,05
	1,20	0,76	0,87	1,04	1,26	1,26	1,26	1,26
N _{2,ilk} [kN]	0,76	0,87	1,04	1,28	1,58	1,86	2,42	
M _{2,perm} [Nm]								

The pull-through-capacities of the grey highlighted values $N_{2,x}$ have been determined according to EN 1999-1-4:2007 section 8.3.3.1 by calculation. This values $N_{2,x}$ may be increased by 6,9% when using the type „S-MS 5x“.

Self piercing screw		Annex 8
Hilti S-MS 41 Z 4,8 x L Hilti S-MS 41 C 4,8 x L Hilti S-MS 51 Z 4,8 x L Hilti S-MS 51 C 4,8 x L with hexagon head and sealing washer $\geq \varnothing 14 \text{ mm}$		

Annex 6:
ETA-10/0182, Annex 9

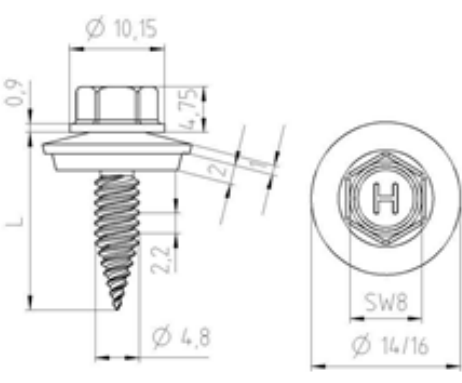

Material:

Fastener: carbon steel, case hardened and galvanized or coated

Washer: carbon steel, galvanized or coated stainless Steel (1.4301) - EN 10088

Component I: aluminium alloy with $R_{m,min} = 165 \text{ N/mm}^2$ - EN 573

Component II: S280GD, S320GD, S350GD - EN 10346

Drilling capacity: $\Sigma t_i \leq 2,50 \text{ mm}$

Timber substructures:
no performance determined

t [mm]	t _i [mm]							
	0,50	0,55	0,63	0,75	0,88	1,00	1,25	
V_{rel} [kN]	0,50	0,55	0,55	0,55	0,55	0,55	0,55	0,55
	0,60	0,55	0,55	0,71	0,71	0,71	0,71	0,71
	0,70	0,55	0,55	0,71	0,88	0,88	0,88	0,88
	0,80	0,55	0,55	0,71	0,88	1,04	1,04	1,04
	1,00	0,55	0,55	0,71	0,88	1,04	1,44	1,44
	1,20	0,55	0,55	0,71	0,88	1,04	1,44	1,83
N_{ex} [kN]	0,50	0,40	0,40	0,40	0,40	0,40	0,40	0,40
	0,60	0,48	0,48	0,48	0,48	0,48	0,48	0,48
	0,70	0,58	0,58	0,58	0,58	0,58	0,58	0,58
	0,80	0,64	0,64	0,64	0,64	0,64	0,64	0,64
	1,00	0,78	0,80	0,80	0,80	0,80	0,80	0,80
	1,20	0,78	0,87	0,96	0,96	0,96	0,96	0,96
N_{R,ilk} [kN]		0,76	0,87	1,04	1,28	1,58	1,86	2,42
M_{torq} [Nm]								

The pull-through-capacities of the grey highlighted values $N_{R,k}$ have been determined according to EN 1999-1-4:2007 section 8.3.3.1 by calculation. This values $N_{R,k}$ may be increased by 6,9% when using the type „S-MS 5x“.

Self piercing screw		Annex 9
Hilti S-MS 41 Z 4,8 x L Hilti S-MS 41 C 4,8 x L Hilti S-MS 51 Z 4,8 x L Hilti S-MS 51 C 4,8 x L with hexagon head and sealing washer $\geq \text{Ø}14 \text{ mm}$		