

BG

ДЕКЛАРАЦИЯ ЗА ЕКСПЛОАТАЦИОННИ ПОКАЗАТЕЛИ

в съответствие с Приложение III на Регламент (ЕС) № 305/2011 (Регламент за строителните продукти)

Винтове S-CD S, S-CDW S на Hilti за сандвич панели
№ Hilti-SF-DoP-009

1. Уникален идентификационен код на типа на продукта: Винтове за закрепване на сандвич панели S-CD S, S-CDW S на Хилти

2. Тип, партиден или сериен номер или друг елемент, който позволява да се идентифицира строителният продукт съгласно изискванията на член 11, параграф 4: Типът и номерът на партидата са показани на опаковката

3. Предвидена употреба или употреби на строителния продукт в съответствие с приложимата хармонизирана техническа спецификация, както е предвидено от производителя:

Настройван тип и употреба	Самонарезни монтажни винтове за сандвич панели
Обхванати размери на продукта	Диаметър на винта 5,5 и 6,5
Материал на основата и закрепван материал	Стомана съгласно EN 10025-1 и EN 10346, Дървен материал съгласно EN 14081
Материал на крепежните елементи	Неръждаема стомана (1.4301, 1.4401 или 1.4571) съгласно EN 10088
Натоварване	Статично и квазистатично (ветрово натоварване)

4. Име, регистрирано търговско наименование или регистрирана търговска марка и адрес за контакт на производителя съгласно изискванията на член 11, параграф 5: Hilti Aktiengesellschaft, Business Unit Direct Fastening, 9494 Schaan, Княжество Лихтенщайн

5. Когато е приложимо, име и адрес за контакт на упълномощения представител, чието пълномощие включва задачите, посочени в член 12, параграф 2: не е приложимо

6. Система или системи за оценяване и проверка на постоянството на експлоатационните показатели на строителния продукт, както са изложени в приложение V: Система 2+

7. В случай на декларация за експлоатационни показатели относно строителен продукт, обхванат от хармонизиран стандарт: не е приложимо

8. В случай на декларация за експлоатационни показатели относно строителен продукт, за който е била издадена Европейска техническа оценка: Deutsches Institut für Bautechnik (DIBt) издаде ETA-13/079 въз основа на EAD 330047-01-0602. Нотифицираният орган MPA-Karlsruhe 0769 изпълни задачи като трета страна по система 2+ и издаде сертификат за съответствие на фабричния производствен контрол 0769-CPR-VAS-00705.

9. Декларирани експлоатационни показатели:

Съществена характеристика	Експлоатационни показатели	Хармонизирана техническа спецификация
Характеристична якост на опън $N_{R,k}$	Приложение 1-16 ETA-13/0179 (Приложение 8-11, 16-27)	ETA 13/0179 EAD 330047-01-0602
Характеристична якост на срязване $V_{R,k}$		
Макс. допустимо преместване на главата на винта u		
Граници на приложение		
Реакция на огън	A1	

10. Експлоатационните показатели на продукта, посочен в точки 1 и 2, са в съответствие с декларираните експлоатационни показатели в точка 9. Настоящата декларация за експлоатационни показатели се издава под единствената отговорност на производителя, посочен в точка 4.

Подписано за и от името на производителя от:

Lars Taenzer

Ръководител на бизнес филиал "Директно закрепване"
Hilti Aktiengesellschaft, Schaan, 01.05.2019 г.

Pierre Hohmeier

Ръководител по качеството "Закрепване с винтове"

Annex 1:
ETA-13/0179, Annex 8

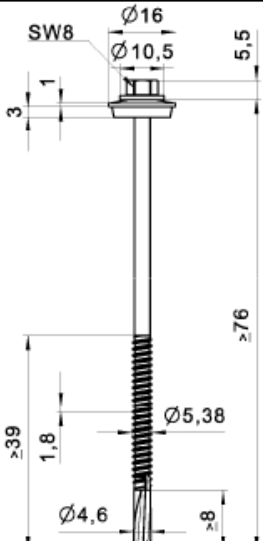

Material:
 Fastener: stainless Steel (1.4301, 1.4401, 1.4571) - EN 10088
 Washer: stainless Steel (1.4301) - EN 10088
 Component I: S280GD, S320GD, S350GD, S390GD, S420GD, S450GD - EN 10346
 Component II: S235, S275, S355, S420 - EN 10025-1, S280GD, S320GD, S350GD, S390GD, S420GD, S450GD - EN 10346

Drilling capacity: $\Sigma t_i \leq 6,00$ mm

Timber substructures:
no performance determined

t_{N1}, t_{N2}, d, D [mm]	t_{ii} [mm]									
	1,50	2,00	2,50	3,00	4,00	5,00	6,00	8,00	≥ 10,0	
$V_{R,k}$ [kN]	0,40	0,65	0,65	0,65	0,65	0,65	0,65	—	—	—
	0,50	1,17	1,17	1,17	1,17	1,17	1,17	—	—	—
	0,55	1,36	1,36	1,36	1,36	1,36	1,36	—	—	—
	0,60	1,54	1,54	1,54	1,54	1,54	1,54	—	—	—
	0,63	1,65	1,65	1,65	1,65	1,65	1,65	—	—	—
	0,75	2,03	2,03	2,03	2,03	2,03	2,03	—	—	—
	0,88	2,40	2,40	2,40	2,40	2,40	2,40	—	—	—
	1,00	2,68	2,68	2,68	2,68	2,68	2,68	—	—	—
$N_{R,k}$ [kN]	0,40	—	—	—	—	—	—	—	—	—
	0,50	1,80	1,92	1,92	1,92	1,92	1,92	—	—	—
	0,55	1,80	2,19	2,19	2,19	2,19	2,19	—	—	—
	0,60	1,80	2,48	2,48	2,48	2,48	2,48	—	—	—
	0,63	1,80	2,65	2,65	2,65	2,65	2,65	—	—	—
	0,75	1,80	2,80	3,57	3,57	3,57	3,57	—	—	—
	0,88	1,80	2,80	3,57	3,57	3,57	3,57	—	—	—
	1,00	1,80	2,80	3,57	3,57	3,57	3,57	—	—	—
u [mm]	40	18,0	8,0	7,0	6,0	5,0	3,0	—	—	—
	50	22,0	10,5	9,0	7,5	6,5	4,3	—	—	—
	60	26,0	13,0	11,0	9,0	8,0	5,5	—	—	—
	70	29,5	16,5	14,0	12,0	11,5	6,8	—	—	—
	80	33,0	20,0	17,5	15,0	14,0	8,0	—	—	—
	100	33,0	20,0	17,5	15,0	14,0	10,0	—	—	—
	120	33,0	20,0	17,5	15,0	14,0	12,0	—	—	—
≥ 140	33,0	20,0	17,5	15,0	14,0	14,0	—	—	—	
$N_{R,k,II}$ [kN]	1,94	2,84	3,83	4,89	7,18	7,18	—	—	—	

If component t_{N1} resp. t_{N2} is made of steel grade higher than S280GD the grey highlighted values may be increased by 8,3%. If both components t_{N1} resp. t_{N2} and t_{ii} are made of steel grade higher than S280GD all values $V_{R,k}$ and $N_{R,k}$ may be increased by 8,3%. If component t_{ii} is made of steel grade higher than S235 or S280GD the values $N_{R,k,II}$ may be increased by 8,3%.

Self drilling screw	Annex 8
Hilti S-CDH 53 S 5,5 x L Hilti S-CDH 53 SS 5,5 x L with hexagon head and sealing washer Ø16 mm	

Annex 2:
ETA-13/0179, Annex 9

Material:
 Fastener: stainless Steel (1.4301, 1.4401, 1.4571) - EN 10088
 Washer: stainless Steel (1.4301) - EN 10088
 Component I: S280GD, S320GD, S350GD, S390GD, S420GD, S450GD - EN 10346
 Component II: S235, S275, S355, S420 - EN 10025-1, S280GD, S320GD, S350GD, S390GD, S420GD, S450GD - EN 10346

Drilling capacity: $\Sigma t_i \leq 6,00$ mm

Timber substructures:
no performance determined

t_{N1}, t_{N2}, d, D [mm]	t_{ii} [mm]									
	1,50	2,00	2,50	3,00	4,00	5,00	6,00	8,00	$\geq 10,0$	
$V_{R,k}$ [kN]	0,40	0,65	0,65	0,65	0,65	0,65	0,65	—	—	—
	0,50	1,17	1,17	1,17	1,17	1,17	1,17	—	—	—
	0,55	1,36	1,36	1,36	1,36	1,36	1,36	—	—	—
	0,60	1,54	1,54	1,54	1,54	1,54	1,54	—	—	—
	0,63	1,65	1,65	1,65	1,65	1,65	1,65	—	—	—
	0,75	2,03	2,03	2,03	2,03	2,03	2,03	—	—	—
	0,88	2,40	2,40	2,40	2,40	2,40	2,40	—	—	—
	1,00	2,68	2,68	2,68	2,68	2,68	2,68	—	—	—
$N_{R,k}$ [kN]	0,40	—	—	—	—	—	—	—	—	—
	0,50	1,80	2,60	2,60	2,60	2,60	2,60	—	—	—
	0,55	1,80	2,80	3,00	3,00	3,00	3,00	—	—	—
	0,60	1,80	2,80	3,25	3,25	3,25	3,25	—	—	—
	0,63	1,80	2,80	3,40	3,40	3,40	3,40	—	—	—
	0,75	1,80	2,80	3,80	4,20	4,20	4,20	—	—	—
	0,88	1,80	2,80	3,80	4,50	4,50	4,50	—	—	—
	1,00	1,80	2,80	3,80	4,50	4,50	4,50	—	—	—
u [mm]	40	18,0	8,0	7,0	6,0	5,0	3,0	—	—	—
	50	22,0	10,5	9,0	7,5	6,5	4,3	—	—	—
	60	26,0	13,0	11,0	9,0	8,0	5,5	—	—	—
	70	29,5	16,5	14,0	12,0	11,5	6,8	—	—	—
	80	33,0	20,0	17,5	15,0	14,0	8,0	—	—	—
	100	33,0	20,0	17,5	15,0	14,0	10,0	—	—	—
	120	33,0	20,0	17,5	15,0	14,0	12,0	—	—	—
≥ 140	33,0	20,0	17,5	15,0	14,0	14,0	—	—	—	
$N_{R,k,II}$ [kN]	1,94	2,84	3,83	4,89	7,18	7,18	—	—	—	

If component t_{N1} resp. t_{N2} is made of steel grade higher than S280GD the grey highlighted values may be increased by 8,3%. If both components t_{N1} resp. t_{N2} and t_{ii} are made of steel grade higher than S280GD all values $V_{R,k}$ and $N_{R,k}$ may be increased by 8,3%. If component t_{ii} is made of steel grade higher than S235 or S280GD the values $N_{R,k,II}$ may be increased by 8,3%.

Self drilling screw	Annex 9
Hilti S-CDH 63 S 5,5 x L Hilti S-CDH 63 SS 5,5 x L Hilti S-CDH 73 S 5,5 x L Hilti S-CDH 73 SS 5,5 x L with hexagon head and sealing washer $\geq \varnothing 19$ mm	

Annex 3:
ETA-13/0179, Annex 10

Material:
 Fastener: stainless Steel (1.4301, 1.4401, 1.4571) - EN 10088
 Washer: stainless Steel (1.4301) - EN 10088
 Component I: S280GD, S320GD, S350GD, S390GD, S420GD, S450GD - EN 10346
 Component II: S235, S275, S355, S420 - EN 10025-1, S280GD, S320GD, S350GD, S390GD, S420GD, S450GD - EN 10346

Drilling capacity: $\Sigma t_i \leq 6,00$ mm

Timber substructures:
no performance determined

t_{N1}, t_{N2}, d, D [mm]	t_{II} [mm]									
	1,50	2,00	2,50	3,00	4,00	5,00	6,00	8,00	≥ 10,0	
$V_{R,k}$ [kN]	0,40	0,65	0,65	0,65	0,65	0,65	0,65	—	—	—
	0,50	1,17	1,17	1,17	1,17	1,17	1,17	—	—	—
	0,55	1,36	1,36	1,36	1,36	1,36	1,36	—	—	—
	0,60	1,54	1,54	1,54	1,54	1,54	1,54	—	—	—
	0,63	1,65	1,65	1,65	1,65	1,65	1,65	—	—	—
	0,75	2,03	2,03	2,03	2,03	2,03	2,03	—	—	—
	0,88	2,40	2,40	2,40	2,40	2,40	2,40	—	—	—
	1,00	2,68	2,68	2,68	2,68	2,68	2,68	—	—	—
$N_{R,k}$ [kN]	0,40	—	—	—	—	—	—	—	—	—
	0,50	1,80	1,92	1,92	1,92	1,92	1,92	—	—	—
	0,55	1,80	2,19	2,19	2,19	2,19	2,19	—	—	—
	0,60	1,80	2,48	2,48	2,48	2,48	2,48	—	—	—
	0,63	1,80	2,65	2,65	2,65	2,65	2,65	—	—	—
	0,75	1,80	2,80	3,57	3,57	3,57	3,57	—	—	—
	0,88	1,80	2,80	3,57	3,57	3,57	3,57	—	—	—
	1,00	1,80	2,80	3,57	3,57	3,57	3,57	—	—	—
u [mm]	40	18,0	8,0	7,0	6,0	5,0	3,0	—	—	—
	50	22,0	10,5	9,0	7,5	6,5	4,3	—	—	—
	60	26,0	13,0	11,0	9,0	8,0	5,5	—	—	—
	70	29,5	16,5	14,0	12,0	11,5	6,8	—	—	—
	80	33,0	20,0	17,5	15,0	14,0	8,0	—	—	—
	100	33,0	20,0	17,5	15,0	14,0	10,0	—	—	—
	120	33,0	20,0	17,5	15,0	14,0	12,0	—	—	—
	≥ 140	33,0	20,0	17,5	15,0	14,0	14,0	—	—	—
$N_{R,k,II}$ [kN]	1,94	2,84	3,83	4,89	7,18	7,18	—	—	—	

If component t_{N1} resp. t_{N2} is made of steel grade higher than S280GD the grey highlighted values may be increased by 8,3%. If both components t_{N1} resp. t_{N2} and t_{II} are made of steel grade higher than S280GD all values $V_{R,k}$ and $N_{R,k}$ may be increased by 8,3%. If component t_{II} is made of steel grade higher than S235 or S280GD the values $N_{R,k,II}$ may be increased by 8,3%.

Self drilling screw	Annex 10
Hilti S-CD 53 S 5,5 x L Hilti S-CD 53 SS 5,5 x L with hexagon head and sealing washer Ø16 mm	

Annex 4:
ETA-13/0179, Annex 11

Material:
 Fastener: stainless Steel (1.4301, 1.4401, 1.4571) - EN 10088
 Washer: stainless Steel (1.4301) - EN 10088
 Component I: S280GD, S320GD, S350GD, S390GD, S420GD, S450GD - EN 10346
 Component II: S235, S275, S355, S420 - EN 10025-1, S280GD, S320GD, S350GD, S390GD, S420GD, S450GD - EN 10346

Drilling capacity: $\Sigma t_i \leq 6,00$ mm

Timber substructures:
no performance determined

t_{N1}, t_{N2}, d, D [mm]	t_{ii} [mm]									
	1,50	2,00	2,50	3,00	4,00	5,00	6,00	8,00	$\geq 10,0$	
$V_{R,k}$ [kN]	0,40	0,65	0,65	0,65	0,65	0,65	0,65	—	—	—
	0,50	1,17	1,17	1,17	1,17	1,17	1,17	—	—	—
	0,55	1,36	1,36	1,36	1,36	1,36	1,36	—	—	—
	0,60	1,54	1,54	1,54	1,54	1,54	1,54	—	—	—
	0,63	1,65	1,65	1,65	1,65	1,65	1,65	—	—	—
	0,75	2,03	2,03	2,03	2,03	2,03	2,03	—	—	—
	0,88	2,40	2,40	2,40	2,40	2,40	2,40	—	—	—
	1,00	2,68	2,68	2,68	2,68	2,68	2,68	—	—	—
$N_{R,k}$ [kN]	0,40	—	—	—	—	—	—	—	—	—
	0,50	1,80	2,60	2,60	2,60	2,60	2,60	—	—	—
	0,55	1,80	2,80	3,00	3,00	3,00	3,00	—	—	—
	0,60	1,80	2,80	3,25	3,25	3,25	3,25	—	—	—
	0,63	1,80	2,80	3,40	3,40	3,40	3,40	—	—	—
	0,75	1,80	2,80	3,80	4,20	4,20	4,20	—	—	—
	0,88	1,80	2,80	3,80	4,50	4,50	4,50	—	—	—
	1,00	1,80	2,80	3,80	4,50	4,50	4,50	—	—	—
u [mm]	40	18,0	8,0	7,0	6,0	5,0	3,0	—	—	—
	50	22,0	10,5	9,0	7,5	6,5	4,3	—	—	—
	60	26,0	13,0	11,0	9,0	8,0	5,5	—	—	—
	70	29,5	16,5	14,0	12,0	11,5	6,8	—	—	—
	80	33,0	20,0	17,5	15,0	14,0	8,0	—	—	—
	100	33,0	20,0	17,5	15,0	14,0	10,0	—	—	—
	120	33,0	20,0	17,5	15,0	14,0	12,0	—	—	—
≥ 140	33,0	20,0	17,5	15,0	14,0	14,0	—	—	—	
$N_{R,k,II}$ [kN]	1,94	2,84	3,83	4,89	7,18	7,18	—	—	—	

If component t_{N1} resp. t_{N2} is made of steel grade higher than S280GD the grey highlighted values may be increased by 8,3%. If both components t_{N1} resp. t_{N2} and t_{ii} are made of steel grade higher than S280GD all values $V_{R,k}$ and $N_{R,k}$ may be increased by 8,3%. If component t_{ii} is made of steel grade higher than S235 or S280GD the values $N_{R,k,II}$ may be increased by 8,3%.

Self drilling screw	Annex 11
Hilti S-CD 63 S 5,5 x L Hilti S-CD 63 SS 5,5 x L Hilti S-CD 73 S 5,5 x L Hilti S-CD 73 SS 5,5 x L with hexagon head and sealing washer $\geq \varnothing 19$ mm	

Annex 5:
ETA-13/0179, Annex 16

Material:
 Fastener: stainless Steel (1.4301, 1.4401, 1.4571) - EN 10088
 Washer: stainless Steel (1.4301) - EN 10088
 Component I: S280GD, S320GD, S350GD - EN 10346
 Component II: S235 - EN 10025-1
 S280GD, S320GD - EN 10346

Drilling capacity: $\Sigma t_i \leq 12,00$ mm

Timber substructures:
no performance determined

t_{N1}, t_{N2}, d, D [mm]	t_{II} [mm]									
	3,00	4,00	5,00	6,00	8,00	9,00	10,0	11,0	$\geq 12,0$	
$V_{R,k}$ [kN]	0,40	0,99	0,99	0,99	0,99	0,99	0,99	0,99	0,99	—
	0,50	1,46	1,46	1,46	1,46	1,46	1,46	1,46	1,46	—
	0,55	1,62	1,62	1,62	1,62	1,62	1,62	1,62	1,62	—
	0,60	1,80	1,80	1,80	1,80	1,80	1,80	1,80	1,80	—
	0,63	1,90	1,90	1,90	1,90	1,90	1,90	1,90	1,90	—
	0,75	2,37	2,37	2,37	2,37	2,37	2,37	2,37	2,37	—
	0,88	2,94	2,94	2,94	2,94	2,94	2,94	2,94	2,94	—
	1,00	3,52	3,52	3,52	3,52	3,52	3,52	3,52	3,52	—
$N_{R,k}$ [kN]	0,40	—	—	—	—	—	—	—	—	—
	0,50	1,96	1,96	1,96	1,96	1,96	1,96	1,96	1,96	—
	0,55	2,25	2,25	2,25	2,25	2,25	2,25	2,25	2,25	—
	0,60	2,57	2,57	2,57	2,57	2,57	2,57	2,57	2,57	—
	0,63	2,76	2,76	2,76	2,76	2,76	2,76	2,76	2,76	—
	0,75	3,49	3,49	3,49	3,49	3,49	3,49	3,49	3,49	—
	0,88	3,49	3,49	3,49	3,49	3,49	3,49	3,49	3,49	—
	1,00	3,49	3,49	3,49	3,49	3,49	3,49	3,49	3,49	—
u [mm]	40	6,0	5,5	5,0	4,0	4,0	4,0	4,0	4,0	—
	50	8,0	7,5	7,0	6,0	6,0	6,0	6,0	6,0	—
	60	10,0	9,5	9,0	8,0	8,0	8,0	8,0	8,0	—
	70	12,5	11,5	11,0	9,5	9,5	9,5	9,5	9,5	—
	80	15,0	14,0	13,0	11,0	11,0	11,0	11,0	11,0	—
	100	15,0	14,0	13,0	11,0	11,0	11,0	11,0	11,0	—
	120	15,0	14,0	13,0	11,0	11,0	11,0	11,0	11,0	—
$N_{R,k,II}$ [kN]	4,65	6,40	7,74	8,36	8,36	8,36	8,36	8,36	—	

If component t_{N1} resp. t_{N2} is made of S320GD or S350GD the grey highlighted values may be increased by 8,3%.
 If component t_{II} is made of S320GD the values $N_{R,k,II}$ may be increased by 8,3%.

Self drilling screw	Annex 16
Hilti S-CDH 55 S 5,5 x L Hilti S-CDH 55 SS 5,5 x L with hexagon head and sealing washer $\varnothing 16$ mm	

Annex 6:
ETA-13/0179, Annex 17

Material:
 Fastener: stainless Steel (1.4301, 1.4401, 1.4571) - EN 10088
 Washer: stainless Steel (1.4301) - EN 10088
 Component I: S280GD, S320GD, S350GD - EN 10346
 Component II: S235 - EN 10025-1
 S280GD, S320GD - EN 10346

Drilling capacity: $\Sigma t_i \leq 12,00$ mm

Timber substructures:
no performance determined

t_{N1}, t_{N2}, d, D [mm]	t_i [mm]									
	3,00	4,00	5,00	6,00	8,00	9,00	10,0	11,0	$\geq 12,0$	
$V_{R,k}$ [kN]	0,40	0,99	0,99	0,99	0,99	0,99	0,99	0,99	0,99	—
	0,50	1,46	1,46	1,46	1,46	1,46	1,46	1,46	1,46	—
	0,55	1,62	1,62	1,62	1,62	1,62	1,62	1,62	1,62	—
	0,60	1,80	1,80	1,80	1,80	1,80	1,80	1,80	1,80	—
	0,63	1,90	1,90	1,90	1,90	1,90	1,90	1,90	1,90	—
	0,75	2,37	2,37	2,37	2,37	2,37	2,37	2,37	2,37	—
	0,88	2,94	2,94	2,94	2,94	2,94	2,94	2,94	2,94	—
	1,00	3,52	3,52	3,52	3,52	3,52	3,52	3,52	3,52	—
	$N_{R,k}$ [kN]	0,40	—	—	—	—	—	—	—	—
0,50		2,10	2,10	2,10	2,10	2,10	2,10	2,10	2,10	—
0,55		2,50	2,50	2,50	2,50	2,50	2,50	2,50	2,50	—
0,60		2,75	2,75	2,75	2,75	2,75	2,75	2,75	2,75	—
0,63		2,90	2,90	2,90	2,90	2,90	2,90	2,90	2,90	—
0,75		3,70	3,70	3,70	3,70	3,70	3,70	3,70	3,70	—
0,88		4,50	4,60	4,60	4,60	4,60	4,60	4,60	4,60	—
1,00		4,50	5,20	5,20	5,20	5,20	5,20	5,20	5,20	—
u [mm]		40	6,0	5,5	5,0	4,0	4,0	4,0	4,0	4,0
	50	8,0	7,5	7,0	6,0	6,0	6,0	6,0	6,0	—
	60	10,0	9,5	9,0	8,0	8,0	8,0	8,0	8,0	—
	70	12,5	11,5	11,0	9,5	9,5	9,5	9,5	9,5	—
	80	15,0	14,0	13,0	11,0	11,0	11,0	11,0	11,0	—
	100	15,0	14,0	13,0	11,0	11,0	11,0	11,0	11,0	—
	120	15,0	14,0	13,0	11,0	11,0	11,0	11,0	11,0	—
≥ 140	15,0	14,0	13,0	11,0	11,0	11,0	11,0	11,0	—	
$N_{R,k,II}$ [kN]	4,65	6,40	7,74	8,36	8,36	8,36	8,36	8,36	8,36	—

If component t_{N1} resp. t_{N2} is made of S320GD or S350GD the grey highlighted values may be increased by 8,3%. If both components t_{N1} and t_i are made of S320GD or S350GD the values $N_{R,k}$ may be increased by 8,3%.
 If component t_i is made of S320GD the values $N_{R,k,II}$ may be increased by 8,3%.

Self drilling screw	Annex 17
Hilti S-CDH 65 S 5,5 x L Hilti S-CDH 65 SS 5,5 x L Hilti S-CDH 75 S 5,5 x L Hilti S-CDH 75 SS 5,5 x L with hexagon head and sealing washer $\geq \text{Ø}19$ mm	

Annex 7:
ETA-13/0179, Annex 18

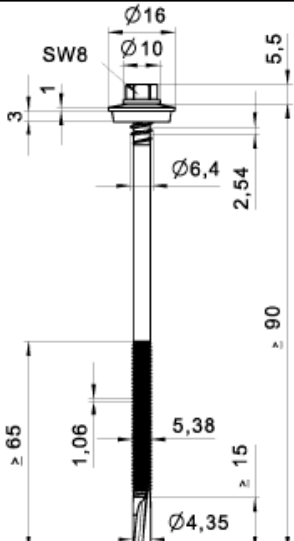

Material:
 Fastener: stainless Steel (1.4301, 1.4401, 1.4571) - EN 10088
 Washer: stainless Steel (1.4301) - EN 10088
 Component I: S280GD, S320GD, S350GD - EN 10346
 Component II: S235 - EN 10025-1
 S280GD, S320GD - EN 10346

Drilling capacity: $\Sigma t_i \leq 12,00$ mm

Timber substructures:
no performance determined

t_{N1}, t_{N2}, d, D [mm]	t_{II} [mm]									
	3,00	4,00	5,00	6,00	8,00	9,00	10,0	11,0	≥ 12,0	
$V_{R,k}$ [kN]	0,40	0,99	0,99	0,99	0,99	0,99	0,99	0,99	0,99	—
	0,50	1,46	1,46	1,46	1,46	1,46	1,46	1,46	1,46	—
	0,55	1,62	1,62	1,62	1,62	1,62	1,62	1,62	1,62	—
	0,60	1,80	1,80	1,80	1,80	1,80	1,80	1,80	1,80	—
	0,63	1,90	1,90	1,90	1,90	1,90	1,90	1,90	1,90	—
	0,75	2,37	2,37	2,37	2,37	2,37	2,37	2,37	2,37	—
	0,88	2,94	2,94	2,94	2,94	2,94	2,94	2,94	2,94	—
	1,00	3,52	3,52	3,52	3,52	3,52	3,52	3,52	3,52	—
	$N_{R,k}$ [kN]	0,40	—	—	—	—	—	—	—	—
0,50		1,96	1,96	1,96	1,96	1,96	1,96	1,96	1,96	—
0,55		2,25	2,25	2,25	2,25	2,25	2,25	2,25	2,25	—
0,60		2,57	2,57	2,57	2,57	2,57	2,57	2,57	2,57	—
0,63		2,76	2,76	2,76	2,76	2,76	2,76	2,76	2,76	—
0,75		3,49	3,49	3,49	3,49	3,49	3,49	3,49	3,49	—
0,88		3,49	3,49	3,49	3,49	3,49	3,49	3,49	3,49	—
1,00		3,49	3,49	3,49	3,49	3,49	3,49	3,49	3,49	—
u [mm]		40	6,0	5,5	5,0	4,0	4,0	4,0	4,0	4,0
	50	8,0	7,5	7,0	6,0	6,0	6,0	6,0	6,0	—
	60	10,0	9,5	9,0	8,0	8,0	8,0	8,0	8,0	—
	70	12,5	11,5	11,0	9,5	9,5	9,5	9,5	9,5	—
	80	15,0	14,0	13,0	11,0	11,0	11,0	11,0	11,0	—
	100	15,0	14,0	13,0	11,0	11,0	11,0	11,0	11,0	—
	≥ 140	15,0	14,0	13,0	11,0	11,0	11,0	11,0	11,0	—
$N_{R,k,II}$ [kN]	4,65	6,40	7,74	8,36	8,36	8,36	8,36	8,36	—	

If component t_{N1} resp. t_{N2} is made of S320GD or S350GD the grey highlighted values may be increased by 8,3%.
 If component t_{II} is made of S320GD the values $N_{R,k,II}$ may be increased by 8,3%.

Self drilling screw	Annex 18
Hilti S-CD 55 S 5,5 x L Hilti S-CD 55 SS 5,5 x L with hexagon head and sealing washer Ø16 mm	

Annex 8:
ETA-13/0179, Annex 19

Material:
 Fastener: stainless Steel (1.4301, 1.4401, 1.4571) - EN 10088
 Washer: stainless Steel (1.4301) - EN 10088
 Component I: S280GD, S320GD, S350GD - EN 10346
 Component II: S235 - EN 10025-1
 S280GD, S320GD - EN 10346

Drilling capacity: $\Sigma t_i \leq 12,00$ mm

Timber substructures:
no performance determined

t_{N1}, t_{N2}, d, D [mm]	t_{II} [mm]									
	3,00	4,00	5,00	6,00	8,00	9,00	10,0	11,0	$\geq 12,0$	
$V_{R,k}$ [kN]	0,40	0,99	0,99	0,99	0,99	0,99	0,99	0,99	0,99	—
	0,50	1,46	1,46	1,46	1,46	1,46	1,46	1,46	1,46	—
	0,55	1,62	1,62	1,62	1,62	1,62	1,62	1,62	1,62	—
	0,60	1,80	1,80	1,80	1,80	1,80	1,80	1,80	1,80	—
	0,63	1,90	1,90	1,90	1,90	1,90	1,90	1,90	1,90	—
	0,75	2,37	2,37	2,37	2,37	2,37	2,37	2,37	2,37	—
	0,88	2,94	2,94	2,94	2,94	2,94	2,94	2,94	2,94	—
	1,00	3,52	3,52	3,52	3,52	3,52	3,52	3,52	3,52	—
$N_{R,k}$ [kN]	0,40	—	—	—	—	—	—	—	—	—
	0,50	2,10	2,10	2,10	2,10	2,10	2,10	2,10	2,10	—
	0,55	2,50	2,50	2,50	2,50	2,50	2,50	2,50	2,50	—
	0,60	2,75	2,75	2,75	2,75	2,75	2,75	2,75	2,75	—
	0,63	2,90	2,90	2,90	2,90	2,90	2,90	2,90	2,90	—
	0,75	3,70	3,70	3,70	3,70	3,70	3,70	3,70	3,70	—
	0,88	4,50	4,60	4,60	4,60	4,60	4,60	4,60	4,60	—
	1,00	4,50	5,20	5,20	5,20	5,20	5,20	5,20	5,20	—
u [mm]	40	6,0	5,5	5,0	4,0	4,0	4,0	4,0	4,0	—
	50	8,0	7,5	7,0	6,0	6,0	6,0	6,0	6,0	—
	60	10,0	9,5	9,0	8,0	8,0	8,0	8,0	8,0	—
	70	12,5	11,5	11,0	9,5	9,5	9,5	9,5	9,5	—
	80	15,0	14,0	13,0	11,0	11,0	11,0	11,0	11,0	—
	100	15,0	14,0	13,0	11,0	11,0	11,0	11,0	11,0	—
	120	15,0	14,0	13,0	11,0	11,0	11,0	11,0	11,0	—
≥ 140	15,0	14,0	13,0	11,0	11,0	11,0	11,0	11,0	—	
$N_{R,k,II}$ [kN]	4,65	6,40	7,74	8,36	8,36	8,36	8,36	8,36	—	

If component t_{N1} resp. t_{N2} is made of S320GD or S350GD the grey highlighted values may be increased by 8,3%. If both components t_{N1} and t_{II} are made of S320GD or S350GD the values $N_{R,k}$ may be increased by 8,3%.
 If component t_{II} is made of S320GD the values $N_{R,k,II}$ may be increased by 8,3%.

Self drilling screw	Annex 19
Hilti S-CD 65 S 5,5 x L Hilti S-CD 65 SS 5,5 x L Hilti S-CD 75 S 5,5 x L Hilti S-CD 75 SS 5,5 x L with hexagon head and sealing washer $\geq \varnothing 19$ mm	

Annex 9:
ETA-13/0179, Annex 20

	Material: Fastener: stainless Steel (1.4301, 1.4401, 1.4571) - EN 10088 Washer: stainless Steel (1.4301) - EN 10088 Component I: S280GD, S320GD, S350GD - EN 10346 Component II: S235, S275, S355 - EN 10025-1 S280GD, S320GD, S350GD - EN 10346																																																																																																																																																																																																																																																																												
	Drilling capacity: $\Sigma t_i \leq 15,00$ mm																																																																																																																																																																																																																																																																												
	Timber substructures: no performance determined																																																																																																																																																																																																																																																																												
<table border="1"> <thead> <tr> <th rowspan="2">t_{N1}, t_{N2}, d, D [mm]</th> <th colspan="6">t_{II} [mm]</th> <th rowspan="2">—</th> <th rowspan="2">—</th> <th rowspan="2">—</th> </tr> <tr> <th>4,00</th> <th>5,00</th> <th>6,00</th> <th>7,00</th> <th>8,00</th> <th>$\geq 10,0$</th> </tr> </thead> <tbody> <tr> <td rowspan="8">$V_{R,k}$ [kN]</td> <td>0,40</td><td>0,82</td><td>0,82</td><td>0,82</td><td>0,82</td><td>0,82</td><td>0,82</td><td>—</td><td>—</td><td>—</td> </tr> <tr> <td>0,50</td><td>0,93</td><td>0,93</td><td>0,93</td><td>0,93</td><td>0,93</td><td>0,93</td><td>—</td><td>—</td><td>—</td> </tr> <tr> <td>0,55</td><td>1,12</td><td>1,12</td><td>1,12</td><td>1,12</td><td>1,12</td><td>1,12</td><td>—</td><td>—</td><td>—</td> </tr> <tr> <td>0,60</td><td>1,31</td><td>1,31</td><td>1,31</td><td>1,31</td><td>1,31</td><td>1,31</td><td>—</td><td>—</td><td>—</td> </tr> <tr> <td>0,63</td><td>1,42</td><td>1,42</td><td>1,42</td><td>1,42</td><td>1,42</td><td>1,42</td><td>—</td><td>—</td><td>—</td> </tr> <tr> <td>0,75</td><td>1,88</td><td>1,88</td><td>1,88</td><td>1,88</td><td>1,88</td><td>1,88</td><td>—</td><td>—</td><td>—</td> </tr> <tr> <td>0,88</td><td>2,33</td><td>2,33</td><td>2,33</td><td>2,33</td><td>2,33</td><td>2,33</td><td>—</td><td>—</td><td>—</td> </tr> <tr> <td>1,00</td><td>2,74</td><td>2,74</td><td>2,74</td><td>2,74</td><td>2,74</td><td>2,74</td><td>—</td><td>—</td><td>—</td> </tr> <tr> <td rowspan="8">$N_{R,k}$ [kN]</td> <td>0,40</td><td>1,46</td><td>1,46</td><td>1,46</td><td>1,46</td><td>1,46</td><td>1,46</td><td>—</td><td>—</td><td>—</td> </tr> <tr> <td>0,50</td><td>1,89</td><td>1,89</td><td>1,89</td><td>1,89</td><td>1,89</td><td>1,89</td><td>—</td><td>—</td><td>—</td> </tr> <tr> <td>0,55</td><td>2,21</td><td>2,21</td><td>2,21</td><td>2,21</td><td>2,21</td><td>2,21</td><td>—</td><td>—</td><td>—</td> </tr> <tr> <td>0,60</td><td>2,53</td><td>2,53</td><td>2,53</td><td>2,53</td><td>2,53</td><td>2,53</td><td>—</td><td>—</td><td>—</td> </tr> <tr> <td>0,63</td><td>2,73</td><td>2,73</td><td>2,73</td><td>2,73</td><td>2,73</td><td>2,73</td><td>—</td><td>—</td><td>—</td> </tr> <tr> <td>0,75</td><td>3,50</td><td>3,50</td><td>3,50</td><td>3,50</td><td>3,50</td><td>3,50</td><td>—</td><td>—</td><td>—</td> </tr> <tr> <td>0,88</td><td>3,68</td><td>3,68</td><td>3,68</td><td>3,68</td><td>3,68</td><td>3,68</td><td>—</td><td>—</td><td>—</td> </tr> <tr> <td>1,00</td><td>3,84</td><td>3,84</td><td>3,84</td><td>3,84</td><td>3,84</td><td>3,84</td><td>—</td><td>—</td><td>—</td> </tr> <tr> <td rowspan="6">u [mm]</td> <td>40</td><td>3,0</td><td>3,0</td><td>3,0</td><td>3,0</td><td>3,0</td><td>3,0</td><td>—</td><td>—</td><td>—</td> </tr> <tr> <td>50</td><td>4,5</td><td>4,5</td><td>4,5</td><td>4,5</td><td>4,5</td><td>4,5</td><td>—</td><td>—</td><td>—</td> </tr> <tr> <td>60</td><td>6,0</td><td>6,0</td><td>6,0</td><td>6,0</td><td>6,0</td><td>6,0</td><td>—</td><td>—</td><td>—</td> </tr> <tr> <td>70</td><td>7,4</td><td>7,4</td><td>7,4</td><td>7,4</td><td>7,4</td><td>7,4</td><td>—</td><td>—</td><td>—</td> </tr> <tr> <td>80</td><td>8,8</td><td>8,8</td><td>8,8</td><td>8,8</td><td>8,8</td><td>8,8</td><td>—</td><td>—</td><td>—</td> </tr> <tr> <td>90</td><td>10,1</td><td>10,1</td><td>10,1</td><td>10,1</td><td>10,1</td><td>10,1</td><td>—</td><td>—</td><td>—</td> </tr> <tr> <td>≥ 100</td><td>11,5</td><td>11,5</td><td>11,5</td><td>11,5</td><td>11,5</td><td>11,5</td><td>—</td><td>—</td><td>—</td> </tr> <tr> <td>$N_{R,k,II}$ [kN]</td> <td>3,92</td><td>4,92</td><td>5,91</td><td>6,22</td><td>6,52</td><td>6,52</td><td>—</td><td>—</td><td>—</td> </tr> </tbody> </table>	t_{N1}, t_{N2}, d, D [mm]	t_{II} [mm]						—	—	—	4,00	5,00	6,00	7,00	8,00	$\geq 10,0$	$V_{R,k}$ [kN]	0,40	0,82	0,82	0,82	0,82	0,82	0,82	—	—	—	0,50	0,93	0,93	0,93	0,93	0,93	0,93	—	—	—	0,55	1,12	1,12	1,12	1,12	1,12	1,12	—	—	—	0,60	1,31	1,31	1,31	1,31	1,31	1,31	—	—	—	0,63	1,42	1,42	1,42	1,42	1,42	1,42	—	—	—	0,75	1,88	1,88	1,88	1,88	1,88	1,88	—	—	—	0,88	2,33	2,33	2,33	2,33	2,33	2,33	—	—	—	1,00	2,74	2,74	2,74	2,74	2,74	2,74	—	—	—	$N_{R,k}$ [kN]	0,40	1,46	1,46	1,46	1,46	1,46	1,46	—	—	—	0,50	1,89	1,89	1,89	1,89	1,89	1,89	—	—	—	0,55	2,21	2,21	2,21	2,21	2,21	2,21	—	—	—	0,60	2,53	2,53	2,53	2,53	2,53	2,53	—	—	—	0,63	2,73	2,73	2,73	2,73	2,73	2,73	—	—	—	0,75	3,50	3,50	3,50	3,50	3,50	3,50	—	—	—	0,88	3,68	3,68	3,68	3,68	3,68	3,68	—	—	—	1,00	3,84	3,84	3,84	3,84	3,84	3,84	—	—	—	u [mm]	40	3,0	3,0	3,0	3,0	3,0	3,0	—	—	—	50	4,5	4,5	4,5	4,5	4,5	4,5	—	—	—	60	6,0	6,0	6,0	6,0	6,0	6,0	—	—	—	70	7,4	7,4	7,4	7,4	7,4	7,4	—	—	—	80	8,8	8,8	8,8	8,8	8,8	8,8	—	—	—	90	10,1	10,1	10,1	10,1	10,1	10,1	—	—	—	≥ 100	11,5	11,5	11,5	11,5	11,5	11,5	—	—	—	$N_{R,k,II}$ [kN]	3,92	4,92	5,91	6,22	6,52	6,52	—	—	—	No additional regulations.									
t_{N1}, t_{N2}, d, D [mm]		t_{II} [mm]									—	—	—																																																																																																																																																																																																																																																																
	4,00	5,00	6,00	7,00	8,00	$\geq 10,0$																																																																																																																																																																																																																																																																							
$V_{R,k}$ [kN]	0,40	0,82	0,82	0,82	0,82	0,82	0,82	—	—	—																																																																																																																																																																																																																																																																			
	0,50	0,93	0,93	0,93	0,93	0,93	0,93	—	—	—																																																																																																																																																																																																																																																																			
	0,55	1,12	1,12	1,12	1,12	1,12	1,12	—	—	—																																																																																																																																																																																																																																																																			
	0,60	1,31	1,31	1,31	1,31	1,31	1,31	—	—	—																																																																																																																																																																																																																																																																			
	0,63	1,42	1,42	1,42	1,42	1,42	1,42	—	—	—																																																																																																																																																																																																																																																																			
	0,75	1,88	1,88	1,88	1,88	1,88	1,88	—	—	—																																																																																																																																																																																																																																																																			
	0,88	2,33	2,33	2,33	2,33	2,33	2,33	—	—	—																																																																																																																																																																																																																																																																			
	1,00	2,74	2,74	2,74	2,74	2,74	2,74	—	—	—																																																																																																																																																																																																																																																																			
$N_{R,k}$ [kN]	0,40	1,46	1,46	1,46	1,46	1,46	1,46	—	—	—																																																																																																																																																																																																																																																																			
	0,50	1,89	1,89	1,89	1,89	1,89	1,89	—	—	—																																																																																																																																																																																																																																																																			
	0,55	2,21	2,21	2,21	2,21	2,21	2,21	—	—	—																																																																																																																																																																																																																																																																			
	0,60	2,53	2,53	2,53	2,53	2,53	2,53	—	—	—																																																																																																																																																																																																																																																																			
	0,63	2,73	2,73	2,73	2,73	2,73	2,73	—	—	—																																																																																																																																																																																																																																																																			
	0,75	3,50	3,50	3,50	3,50	3,50	3,50	—	—	—																																																																																																																																																																																																																																																																			
	0,88	3,68	3,68	3,68	3,68	3,68	3,68	—	—	—																																																																																																																																																																																																																																																																			
	1,00	3,84	3,84	3,84	3,84	3,84	3,84	—	—	—																																																																																																																																																																																																																																																																			
u [mm]	40	3,0	3,0	3,0	3,0	3,0	3,0	—	—	—																																																																																																																																																																																																																																																																			
	50	4,5	4,5	4,5	4,5	4,5	4,5	—	—	—																																																																																																																																																																																																																																																																			
	60	6,0	6,0	6,0	6,0	6,0	6,0	—	—	—																																																																																																																																																																																																																																																																			
	70	7,4	7,4	7,4	7,4	7,4	7,4	—	—	—																																																																																																																																																																																																																																																																			
	80	8,8	8,8	8,8	8,8	8,8	8,8	—	—	—																																																																																																																																																																																																																																																																			
	90	10,1	10,1	10,1	10,1	10,1	10,1	—	—	—																																																																																																																																																																																																																																																																			
≥ 100	11,5	11,5	11,5	11,5	11,5	11,5	—	—	—																																																																																																																																																																																																																																																																				
$N_{R,k,II}$ [kN]	3,92	4,92	5,91	6,22	6,52	6,52	—	—	—																																																																																																																																																																																																																																																																				
Self drilling screw																																																																																																																																																																																																																																																																													
Hilti S-CDH 55 GS 5,5 x L Hilti S-CDH 55 GSS 5,5 x L with hexagon head and sealing washer Ø16 mm																																																																																																																																																																																																																																																																													
Annex 20																																																																																																																																																																																																																																																																													

Annex 10:
ETA-13/0179, Annex 21

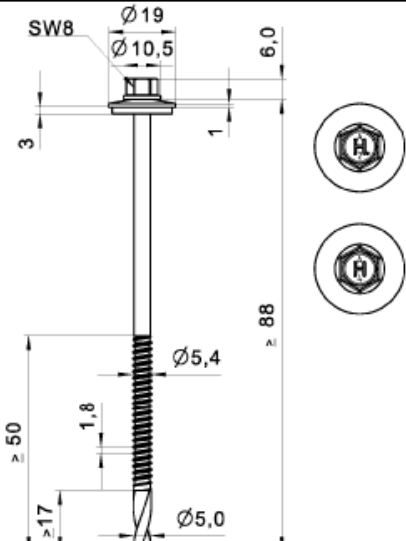

Material:
 Fastener: stainless Steel (1.4301, 1.4401, 1.4571) - EN 10088
 Washer: stainless Steel (1.4301) - EN 10088
 Component I: S280GD, S320GD, S350GD - EN 10346
 Component II: S235, S275, S355 - EN 10025-1
 S280GD, S320GD, S350GD - EN 10346

Drilling capacity: $\Sigma t_i \leq 15,00$ mm

Timber substructures:
no performance determined

	t_{N1}, t_{N2}, d, D [mm]	t_{II} [mm]								
		4,00	5,00	6,00	7,00	8,00	$\geq 10,0$	—	—	—
$V_{R,k}$ [kN]	0,40	0,82	0,82	0,82	0,82	0,82	0,82	—	—	—
	0,50	0,93	1,12	1,30	1,30	1,30	1,30	—	—	—
	0,55	1,12	1,28	1,44	1,44	1,44	1,44	—	—	—
	0,60	1,31	1,45	1,58	1,58	1,58	1,58	—	—	—
	0,63	1,42	1,54	1,66	1,66	1,66	1,66	—	—	—
	0,75	1,88	1,94	2,00	2,00	2,00	2,00	—	—	—
	0,88	2,33	2,57	2,81	2,81	2,81	2,81	—	—	—
	1,00	2,74	3,15	3,56	3,56	3,56	3,56	—	—	—
$N_{R,k}$ [kN]	0,40	1,46	1,46	1,46	1,46	1,46	1,46	—	—	—
	0,50	1,89	1,89	1,89	1,89	1,89	1,89	—	—	—
	0,55	2,21	2,21	2,21	2,21	2,21	2,21	—	—	—
	0,60	2,53	2,53	2,53	2,53	2,53	2,53	—	—	—
	0,63	2,73	2,73	2,73	2,73	2,73	2,73	—	—	—
	0,75	3,50	3,50	3,50	3,50	3,50	3,50	—	—	—
	0,88	3,68	3,68	3,68	3,68	3,68	3,68	—	—	—
	1,00	3,84	3,84	3,84	3,84	3,84	3,84	—	—	—
u [mm]	40	3,0	3,0	3,0	3,0	3,0	3,0	—	—	—
	50	4,5	4,5	4,5	4,5	4,5	4,5	—	—	—
	60	6,0	6,0	6,0	6,0	6,0	6,0	—	—	—
	70	7,4	7,4	7,4	7,4	7,4	7,4	—	—	—
	80	8,8	8,8	8,8	8,8	8,8	8,8	—	—	—
	90	10,1	10,1	10,1	10,1	10,1	10,1	—	—	—
≥ 100	11,5	11,5	11,5	11,5	11,5	11,5	—	—	—	
$N_{R,k,II}$ [kN]		3,92	4,92	5,91	6,22	6,52	6,52	—	—	—

No additional regulations.

Self drilling screw

Hilti S-CDH 65 GS 5,5 x L
 Hilti S-CDH 65 GSS 5,5 x L
 with hexagon head and sealing washer $\varnothing 19$ mm

Annex 21

Annex 11:
ETA-13/0179, Annex 22

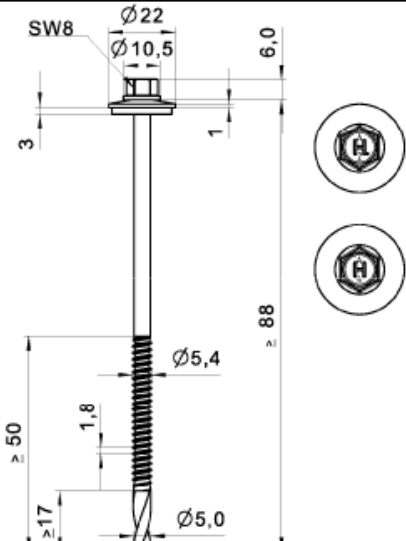

Material:
 Fastener: stainless Steel (1.4301, 1.4401, 1.4571) - EN 10088
 Washer: stainless Steel (1.4301) - EN 10088
 Component I: S280GD, S320GD, S350GD - EN 10346
 Component II: S235, S275, S355 - EN 10025-1
 S280GD, S320GD, S350GD - EN 10346

Drilling capacity: $\Sigma t_i \leq 15,00$ mm

Timber substructures:
no performance determined

t_{N1}, t_{N2}, d, D [mm]	t_{II} [mm]									
	4,00	5,00	6,00	7,00	8,00	$\geq 10,0$	—	—	—	—
$V_{R,k}$ [kN]	0,40	0,82	0,82	0,82	0,82	0,82	0,82	—	—	—
	0,50	0,93	1,12	1,30	1,30	1,30	1,30	—	—	—
	0,55	1,12	1,28	1,44	1,44	1,44	1,44	—	—	—
	0,60	1,31	1,45	1,58	1,58	1,58	1,58	—	—	—
	0,63	1,42	1,54	1,66	1,66	1,66	1,66	—	—	—
	0,75	1,88	1,94	2,00	2,00	2,00	2,00	—	—	—
	0,88	2,33	2,57	2,81	2,81	2,81	2,81	—	—	—
	1,00	2,74	3,15	3,56	3,56	3,56	3,56	—	—	—
$N_{R,k}$ [kN]	0,40	1,65	1,65	1,65	1,65	1,65	1,65	—	—	—
	0,50	1,77	1,77	1,77	1,77	1,77	1,77	—	—	—
	0,55	2,26	2,26	2,26	2,26	2,26	2,26	—	—	—
	0,60	2,74	2,74	2,74	2,74	2,74	2,74	—	—	—
	0,63	3,03	3,03	3,03	3,03	3,03	3,03	—	—	—
	0,75	3,92	4,20	4,20	4,20	4,20	4,20	—	—	—
	0,88	3,92	4,32	4,32	4,32	4,32	4,32	—	—	—
	1,00	3,92	4,44	4,44	4,44	4,44	4,44	—	—	—
u [mm]	40	3,0	3,0	3,0	3,0	3,0	3,0	—	—	—
	50	4,5	4,5	4,5	4,5	4,5	4,5	—	—	—
	60	6,0	6,0	6,0	6,0	6,0	6,0	—	—	—
	70	7,4	7,4	7,4	7,4	7,4	7,4	—	—	—
	80	8,8	8,8	8,8	8,8	8,8	8,8	—	—	—
	90	10,1	10,1	10,1	10,1	10,1	10,1	—	—	—
	≥ 100	11,5	11,5	11,5	11,5	11,5	11,5	—	—	—
$N_{R,k,II}$ [kN]	3,92	4,92	5,91	6,22	6,52	6,52	—	—	—	

No additional regulations.

Self drilling screw

Hilti S-CDH 75 GS 5,5 x L
 Hilti S-CDH 75 GSS 5,5 x L
 with hexagon head and sealing washer $\varnothing 22$ mm

Annex 22

Annex 12:
ETA-13/0179, Annex 23

Material:
 Fastener: stainless Steel (1.4301, 1.4401, 1.4571) - EN 10088
 Washer: stainless Steel (1.4301) - EN 10088
 Component I: S280GD, S320GD, S350GD - EN 10346
 Component II: S235, S275, S355 - EN 10025-1
 S280GD, S320GD, S350GD - EN 10346

Drilling capacity: $\Sigma t_i \leq 15,00$ mm

Timber substructures:
no performance determined

t_{N1}, t_{N2}, d, D [mm]	t_{II} [mm]										
	4,00	5,00	6,00	7,00	8,00	$\geq 10,0$	—	—	—	—	
$V_{R,k}$ [kN]	0,40	0,82	0,82	0,82	0,82	0,82	0,82	—	—	—	—
	0,50	0,93	0,93	0,93	0,93	0,93	0,93	—	—	—	—
	0,55	1,12	1,12	1,12	1,12	1,12	1,12	—	—	—	—
	0,60	1,31	1,31	1,31	1,31	1,31	1,31	—	—	—	—
	0,63	1,42	1,42	1,42	1,42	1,42	1,42	—	—	—	—
	0,75	1,88	1,88	1,88	1,88	1,88	1,88	—	—	—	—
	0,88	2,33	2,33	2,33	2,33	2,33	2,33	—	—	—	—
	1,00	2,74	2,74	2,74	2,74	2,74	2,74	—	—	—	—
$N_{R,k}$ [kN]	0,40	1,46	1,46	1,46	1,46	1,46	1,46	—	—	—	—
	0,50	1,89	1,89	1,89	1,89	1,89	1,89	—	—	—	—
	0,55	2,21	2,21	2,21	2,21	2,21	2,21	—	—	—	—
	0,60	2,53	2,53	2,53	2,53	2,53	2,53	—	—	—	—
	0,63	2,73	2,73	2,73	2,73	2,73	2,73	—	—	—	—
	0,75	3,50	3,50	3,50	3,50	3,50	3,50	—	—	—	—
	0,88	3,68	3,68	3,68	3,68	3,68	3,68	—	—	—	—
	1,00	3,84	3,84	3,84	3,84	3,84	3,84	—	—	—	—
u [mm]	40	3,0	3,0	3,0	3,0	3,0	3,0	—	—	—	—
	50	4,5	4,5	4,5	4,5	4,5	4,5	—	—	—	—
	60	6,0	6,0	6,0	6,0	6,0	6,0	—	—	—	—
	70	7,4	7,4	7,4	7,4	7,4	7,4	—	—	—	—
	80	8,8	8,8	8,8	8,8	8,8	8,8	—	—	—	—
	90	10,1	10,1	10,1	10,1	10,1	10,1	—	—	—	—
≥ 100	11,5	11,5	11,5	11,5	11,5	11,5	—	—	—	—	
$N_{R,k,II}$ [kN]	3,92	4,92	5,91	6,22	6,52	6,52	—	—	—	—	

No additional regulations.

Self drilling screw

Hilti S-CD 55 GS 5,5 x L
 Hilti S-CD 55 GSS 5,5 x L
 with hexagon head and sealing washer Ø16 mm

Annex 23

Annex 13:
ETA-13/0179, Annex 24

	<p>Material: Fastener: stainless Steel (1.4301, 1.4401, 1.4571) - EN 10088 Washer: stainless Steel (1.4301) - EN 10088 Component I: S280GD, S320GD, S350GD - EN 10346 Component II: S235, S275, S355 - EN 10025-1 S280GD, S320GD, S350GD - EN 10346</p>																																																																																																																																																																																																																																																																						
<p>Drilling capacity: $\Sigma t_i \leq 15,00$ mm</p>																																																																																																																																																																																																																																																																							
<p>Timber substructures: no performance determined</p>																																																																																																																																																																																																																																																																							
<table border="1"> <thead> <tr> <th>t_{N1}, t_{N2}, d, D [mm]</th> <th>4,00</th> <th>5,00</th> <th>6,00</th> <th>7,00</th> <th colspan="4">t_{II} [mm]</th> </tr> <tr> <td></td> <td></td> <td></td> <td></td> <td></td> <th>8,00</th> <th>$\geq 10,0$</th> <th>—</th> <th>—</th> <th>—</th> </tr> </thead> <tbody> <tr> <td rowspan="8">$V_{R,k}$ [kN]</td> <td>0,40</td> <td>0,82</td> <td>0,82</td> <td>0,82</td> <td>0,82</td> <td>0,82</td> <td>0,82</td> <td>—</td> <td>—</td> <td>—</td> </tr> <tr> <td>0,50</td> <td>0,93</td> <td>1,12</td> <td>1,30</td> <td>1,30</td> <td>1,30</td> <td>1,30</td> <td>—</td> <td>—</td> <td>—</td> </tr> <tr> <td>0,55</td> <td>1,12</td> <td>1,28</td> <td>1,44</td> <td>1,44</td> <td>1,44</td> <td>1,44</td> <td>—</td> <td>—</td> <td>—</td> </tr> <tr> <td>0,60</td> <td>1,31</td> <td>1,45</td> <td>1,58</td> <td>1,58</td> <td>1,58</td> <td>1,58</td> <td>—</td> <td>—</td> <td>—</td> </tr> <tr> <td>0,63</td> <td>1,42</td> <td>1,54</td> <td>1,66</td> <td>1,66</td> <td>1,66</td> <td>1,66</td> <td>—</td> <td>—</td> <td>—</td> </tr> <tr> <td>0,75</td> <td>1,88</td> <td>1,94</td> <td>2,00</td> <td>2,00</td> <td>2,00</td> <td>2,00</td> <td>—</td> <td>—</td> <td>—</td> </tr> <tr> <td>0,88</td> <td>2,33</td> <td>2,57</td> <td>2,81</td> <td>2,81</td> <td>2,81</td> <td>2,81</td> <td>—</td> <td>—</td> <td>—</td> </tr> <tr> <td>1,00</td> <td>2,74</td> <td>3,15</td> <td>3,56</td> <td>3,56</td> <td>3,56</td> <td>3,56</td> <td>—</td> <td>—</td> <td>—</td> </tr> <tr> <td rowspan="8">$N_{R,k}$ [kN]</td> <td>0,40</td> <td>1,46</td> <td>1,46</td> <td>1,46</td> <td>1,46</td> <td>1,46</td> <td>1,46</td> <td>—</td> <td>—</td> <td>—</td> </tr> <tr> <td>0,50</td> <td>1,89</td> <td>1,89</td> <td>1,89</td> <td>1,89</td> <td>1,89</td> <td>1,89</td> <td>—</td> <td>—</td> <td>—</td> </tr> <tr> <td>0,55</td> <td>2,21</td> <td>2,21</td> <td>2,21</td> <td>2,21</td> <td>2,21</td> <td>2,21</td> <td>—</td> <td>—</td> <td>—</td> </tr> <tr> <td>0,60</td> <td>2,53</td> <td>2,53</td> <td>2,53</td> <td>2,53</td> <td>2,53</td> <td>2,53</td> <td>—</td> <td>—</td> <td>—</td> </tr> <tr> <td>0,63</td> <td>2,73</td> <td>2,73</td> <td>2,73</td> <td>2,73</td> <td>2,73</td> <td>2,73</td> <td>—</td> <td>—</td> <td>—</td> </tr> <tr> <td>0,75</td> <td>3,50</td> <td>3,50</td> <td>3,50</td> <td>3,50</td> <td>3,50</td> <td>3,50</td> <td>—</td> <td>—</td> <td>—</td> </tr> <tr> <td>0,88</td> <td>3,68</td> <td>3,68</td> <td>3,68</td> <td>3,68</td> <td>3,68</td> <td>3,68</td> <td>—</td> <td>—</td> <td>—</td> </tr> <tr> <td>1,00</td> <td>3,84</td> <td>3,84</td> <td>3,84</td> <td>3,84</td> <td>3,84</td> <td>3,84</td> <td>—</td> <td>—</td> <td>—</td> </tr> <tr> <td rowspan="6">u [mm]</td> <td>40</td> <td>3,0</td> <td>3,0</td> <td>3,0</td> <td>3,0</td> <td>3,0</td> <td>3,0</td> <td>—</td> <td>—</td> <td>—</td> </tr> <tr> <td>50</td> <td>4,5</td> <td>4,5</td> <td>4,5</td> <td>4,5</td> <td>4,5</td> <td>4,5</td> <td>—</td> <td>—</td> <td>—</td> </tr> <tr> <td>60</td> <td>6,0</td> <td>6,0</td> <td>6,0</td> <td>6,0</td> <td>6,0</td> <td>6,0</td> <td>—</td> <td>—</td> <td>—</td> </tr> <tr> <td>70</td> <td>7,4</td> <td>7,4</td> <td>7,4</td> <td>7,4</td> <td>7,4</td> <td>7,4</td> <td>—</td> <td>—</td> <td>—</td> </tr> <tr> <td>80</td> <td>8,8</td> <td>8,8</td> <td>8,8</td> <td>8,8</td> <td>8,8</td> <td>8,8</td> <td>—</td> <td>—</td> <td>—</td> </tr> <tr> <td>90</td> <td>10,1</td> <td>10,1</td> <td>10,1</td> <td>10,1</td> <td>10,1</td> <td>10,1</td> <td>—</td> <td>—</td> <td>—</td> </tr> <tr> <td>≥ 100</td> <td>11,5</td> <td>11,5</td> <td>11,5</td> <td>11,5</td> <td>11,5</td> <td>11,5</td> <td>—</td> <td>—</td> <td>—</td> </tr> <tr> <td>$N_{R,k,II}$ [kN]</td> <td>3,92</td> <td>4,92</td> <td>5,91</td> <td>6,22</td> <td>6,52</td> <td>6,52</td> <td>—</td> <td>—</td> <td>—</td> </tr> </tbody> </table>	t_{N1}, t_{N2}, d, D [mm]	4,00	5,00	6,00	7,00	t_{II} [mm]									8,00	$\geq 10,0$	—	—	—	$V_{R,k}$ [kN]	0,40	0,82	0,82	0,82	0,82	0,82	0,82	—	—	—	0,50	0,93	1,12	1,30	1,30	1,30	1,30	—	—	—	0,55	1,12	1,28	1,44	1,44	1,44	1,44	—	—	—	0,60	1,31	1,45	1,58	1,58	1,58	1,58	—	—	—	0,63	1,42	1,54	1,66	1,66	1,66	1,66	—	—	—	0,75	1,88	1,94	2,00	2,00	2,00	2,00	—	—	—	0,88	2,33	2,57	2,81	2,81	2,81	2,81	—	—	—	1,00	2,74	3,15	3,56	3,56	3,56	3,56	—	—	—	$N_{R,k}$ [kN]	0,40	1,46	1,46	1,46	1,46	1,46	1,46	—	—	—	0,50	1,89	1,89	1,89	1,89	1,89	1,89	—	—	—	0,55	2,21	2,21	2,21	2,21	2,21	2,21	—	—	—	0,60	2,53	2,53	2,53	2,53	2,53	2,53	—	—	—	0,63	2,73	2,73	2,73	2,73	2,73	2,73	—	—	—	0,75	3,50	3,50	3,50	3,50	3,50	3,50	—	—	—	0,88	3,68	3,68	3,68	3,68	3,68	3,68	—	—	—	1,00	3,84	3,84	3,84	3,84	3,84	3,84	—	—	—	u [mm]	40	3,0	3,0	3,0	3,0	3,0	3,0	—	—	—	50	4,5	4,5	4,5	4,5	4,5	4,5	—	—	—	60	6,0	6,0	6,0	6,0	6,0	6,0	—	—	—	70	7,4	7,4	7,4	7,4	7,4	7,4	—	—	—	80	8,8	8,8	8,8	8,8	8,8	8,8	—	—	—	90	10,1	10,1	10,1	10,1	10,1	10,1	—	—	—	≥ 100	11,5	11,5	11,5	11,5	11,5	11,5	—	—	—	$N_{R,k,II}$ [kN]	3,92	4,92	5,91	6,22	6,52	6,52	—	—	—	<p>No additional regulations.</p>
t_{N1}, t_{N2}, d, D [mm]	4,00	5,00	6,00	7,00	t_{II} [mm]																																																																																																																																																																																																																																																																		
					8,00	$\geq 10,0$	—	—	—																																																																																																																																																																																																																																																														
$V_{R,k}$ [kN]	0,40	0,82	0,82	0,82	0,82	0,82	0,82	—	—	—																																																																																																																																																																																																																																																													
	0,50	0,93	1,12	1,30	1,30	1,30	1,30	—	—	—																																																																																																																																																																																																																																																													
	0,55	1,12	1,28	1,44	1,44	1,44	1,44	—	—	—																																																																																																																																																																																																																																																													
	0,60	1,31	1,45	1,58	1,58	1,58	1,58	—	—	—																																																																																																																																																																																																																																																													
	0,63	1,42	1,54	1,66	1,66	1,66	1,66	—	—	—																																																																																																																																																																																																																																																													
	0,75	1,88	1,94	2,00	2,00	2,00	2,00	—	—	—																																																																																																																																																																																																																																																													
	0,88	2,33	2,57	2,81	2,81	2,81	2,81	—	—	—																																																																																																																																																																																																																																																													
	1,00	2,74	3,15	3,56	3,56	3,56	3,56	—	—	—																																																																																																																																																																																																																																																													
$N_{R,k}$ [kN]	0,40	1,46	1,46	1,46	1,46	1,46	1,46	—	—	—																																																																																																																																																																																																																																																													
	0,50	1,89	1,89	1,89	1,89	1,89	1,89	—	—	—																																																																																																																																																																																																																																																													
	0,55	2,21	2,21	2,21	2,21	2,21	2,21	—	—	—																																																																																																																																																																																																																																																													
	0,60	2,53	2,53	2,53	2,53	2,53	2,53	—	—	—																																																																																																																																																																																																																																																													
	0,63	2,73	2,73	2,73	2,73	2,73	2,73	—	—	—																																																																																																																																																																																																																																																													
	0,75	3,50	3,50	3,50	3,50	3,50	3,50	—	—	—																																																																																																																																																																																																																																																													
	0,88	3,68	3,68	3,68	3,68	3,68	3,68	—	—	—																																																																																																																																																																																																																																																													
	1,00	3,84	3,84	3,84	3,84	3,84	3,84	—	—	—																																																																																																																																																																																																																																																													
u [mm]	40	3,0	3,0	3,0	3,0	3,0	3,0	—	—	—																																																																																																																																																																																																																																																													
	50	4,5	4,5	4,5	4,5	4,5	4,5	—	—	—																																																																																																																																																																																																																																																													
	60	6,0	6,0	6,0	6,0	6,0	6,0	—	—	—																																																																																																																																																																																																																																																													
	70	7,4	7,4	7,4	7,4	7,4	7,4	—	—	—																																																																																																																																																																																																																																																													
	80	8,8	8,8	8,8	8,8	8,8	8,8	—	—	—																																																																																																																																																																																																																																																													
	90	10,1	10,1	10,1	10,1	10,1	10,1	—	—	—																																																																																																																																																																																																																																																													
≥ 100	11,5	11,5	11,5	11,5	11,5	11,5	—	—	—																																																																																																																																																																																																																																																														
$N_{R,k,II}$ [kN]	3,92	4,92	5,91	6,22	6,52	6,52	—	—	—																																																																																																																																																																																																																																																														
<p style="text-align: center;">Self drilling screw</p> <hr/> <p style="text-align: center;">Hilti S-CD 65 GS 5,5 x L Hilti S-CD 65 GSS 5,5 x L with hexagon head and sealing washer $\varnothing 19$ mm</p> <div style="float: right; text-align: right;">Annex 24</div>																																																																																																																																																																																																																																																																							

Annex 14:
ETA-13/0179, Annex 25

	<p>Material: Fastener: stainless Steel (1.4301, 1.4401, 1.4571) - EN 10088 Washer: stainless Steel (1.4301) - EN 10088 Component I: S280GD, S320GD, S350GD - EN 10346 Component II: S235, S275, S355 - EN 10025-1 S280GD, S320GD, S350GD - EN 10346</p>																																																																																																																																																																																																																																																																																																
<p>Drilling capacity: $\Sigma t_i \leq 15,00$ mm</p>																																																																																																																																																																																																																																																																																																	
<p>Timber substructures: no performance determined</p>																																																																																																																																																																																																																																																																																																	
<table border="1"> <thead> <tr> <th rowspan="2">t_{N1}, t_{N2}, d, D [mm]</th> <th colspan="10">t_{II} [mm]</th> </tr> <tr> <th>4,00</th> <th>5,00</th> <th>6,00</th> <th>7,00</th> <th>8,00</th> <th>$\geq 10,0$</th> <th>—</th> <th>—</th> <th>—</th> <th>—</th> </tr> </thead> <tbody> <tr> <td rowspan="8">$V_{R,k}$ [kN]</td> <td>0,40</td><td>0,82</td><td>0,82</td><td>0,82</td><td>0,82</td><td>0,82</td><td>0,82</td><td>—</td><td>—</td><td>—</td><td>—</td> </tr> <tr> <td>0,50</td><td>0,93</td><td>1,12</td><td>1,30</td><td>1,30</td><td>1,30</td><td>1,30</td><td>—</td><td>—</td><td>—</td><td>—</td> </tr> <tr> <td>0,55</td><td>1,12</td><td>1,28</td><td>1,44</td><td>1,44</td><td>1,44</td><td>1,44</td><td>—</td><td>—</td><td>—</td><td>—</td> </tr> <tr> <td>0,60</td><td>1,31</td><td>1,45</td><td>1,58</td><td>1,58</td><td>1,58</td><td>1,58</td><td>—</td><td>—</td><td>—</td><td>—</td> </tr> <tr> <td>0,63</td><td>1,42</td><td>1,54</td><td>1,66</td><td>1,66</td><td>1,66</td><td>1,66</td><td>—</td><td>—</td><td>—</td><td>—</td> </tr> <tr> <td>0,75</td><td>1,88</td><td>1,94</td><td>2,00</td><td>2,00</td><td>2,00</td><td>2,00</td><td>—</td><td>—</td><td>—</td><td>—</td> </tr> <tr> <td>0,88</td><td>2,33</td><td>2,57</td><td>2,81</td><td>2,81</td><td>2,81</td><td>2,81</td><td>—</td><td>—</td><td>—</td><td>—</td> </tr> <tr> <td>1,00</td><td>2,74</td><td>3,15</td><td>3,56</td><td>3,56</td><td>3,56</td><td>3,56</td><td>—</td><td>—</td><td>—</td><td>—</td> </tr> <tr> <td rowspan="8">$N_{R,k}$ [kN]</td> <td>0,40</td><td>1,65</td><td>1,65</td><td>1,65</td><td>1,65</td><td>1,65</td><td>1,65</td><td>—</td><td>—</td><td>—</td><td>—</td> </tr> <tr> <td>0,50</td><td>1,77</td><td>1,77</td><td>1,77</td><td>1,77</td><td>1,77</td><td>1,77</td><td>—</td><td>—</td><td>—</td><td>—</td> </tr> <tr> <td>0,55</td><td>2,26</td><td>2,26</td><td>2,26</td><td>2,26</td><td>2,26</td><td>2,26</td><td>—</td><td>—</td><td>—</td><td>—</td> </tr> <tr> <td>0,60</td><td>2,74</td><td>2,74</td><td>2,74</td><td>2,74</td><td>2,74</td><td>2,74</td><td>—</td><td>—</td><td>—</td><td>—</td> </tr> <tr> <td>0,63</td><td>3,03</td><td>3,03</td><td>3,03</td><td>3,03</td><td>3,03</td><td>3,03</td><td>—</td><td>—</td><td>—</td><td>—</td> </tr> <tr> <td>0,75</td><td>3,92</td><td>4,20</td><td>4,20</td><td>4,20</td><td>4,20</td><td>4,20</td><td>—</td><td>—</td><td>—</td><td>—</td> </tr> <tr> <td>0,88</td><td>3,92</td><td>4,32</td><td>4,32</td><td>4,32</td><td>4,32</td><td>4,32</td><td>—</td><td>—</td><td>—</td><td>—</td> </tr> <tr> <td>1,00</td><td>3,92</td><td>4,44</td><td>4,44</td><td>4,44</td><td>4,44</td><td>4,44</td><td>—</td><td>—</td><td>—</td><td>—</td> </tr> <tr> <td rowspan="6">u [mm]</td> <td>40</td><td>3,0</td><td>3,0</td><td>3,0</td><td>3,0</td><td>3,0</td><td>3,0</td><td>—</td><td>—</td><td>—</td><td>—</td> </tr> <tr> <td>50</td><td>4,5</td><td>4,5</td><td>4,5</td><td>4,5</td><td>4,5</td><td>4,5</td><td>—</td><td>—</td><td>—</td><td>—</td> </tr> <tr> <td>60</td><td>6,0</td><td>6,0</td><td>6,0</td><td>6,0</td><td>6,0</td><td>6,0</td><td>—</td><td>—</td><td>—</td><td>—</td> </tr> <tr> <td>70</td><td>7,4</td><td>7,4</td><td>7,4</td><td>7,4</td><td>7,4</td><td>7,4</td><td>—</td><td>—</td><td>—</td><td>—</td> </tr> <tr> <td>80</td><td>8,8</td><td>8,8</td><td>8,8</td><td>8,8</td><td>8,8</td><td>8,8</td><td>—</td><td>—</td><td>—</td><td>—</td> </tr> <tr> <td>90</td><td>10,1</td><td>10,1</td><td>10,1</td><td>10,1</td><td>10,1</td><td>10,1</td><td>—</td><td>—</td><td>—</td><td>—</td> </tr> <tr> <td>≥ 100</td><td>11,5</td><td>11,5</td><td>11,5</td><td>11,5</td><td>11,5</td><td>11,5</td><td>—</td><td>—</td><td>—</td><td>—</td> </tr> <tr> <td>$N_{R,k,II}$ [kN]</td> <td>3,92</td><td>4,92</td><td>5,91</td><td>6,22</td><td>6,52</td><td>6,52</td><td>—</td><td>—</td><td>—</td><td>—</td> </tr> </tbody> </table>	t_{N1}, t_{N2}, d, D [mm]	t_{II} [mm]										4,00	5,00	6,00	7,00	8,00	$\geq 10,0$	—	—	—	—	$V_{R,k}$ [kN]	0,40	0,82	0,82	0,82	0,82	0,82	0,82	—	—	—	—	0,50	0,93	1,12	1,30	1,30	1,30	1,30	—	—	—	—	0,55	1,12	1,28	1,44	1,44	1,44	1,44	—	—	—	—	0,60	1,31	1,45	1,58	1,58	1,58	1,58	—	—	—	—	0,63	1,42	1,54	1,66	1,66	1,66	1,66	—	—	—	—	0,75	1,88	1,94	2,00	2,00	2,00	2,00	—	—	—	—	0,88	2,33	2,57	2,81	2,81	2,81	2,81	—	—	—	—	1,00	2,74	3,15	3,56	3,56	3,56	3,56	—	—	—	—	$N_{R,k}$ [kN]	0,40	1,65	1,65	1,65	1,65	1,65	1,65	—	—	—	—	0,50	1,77	1,77	1,77	1,77	1,77	1,77	—	—	—	—	0,55	2,26	2,26	2,26	2,26	2,26	2,26	—	—	—	—	0,60	2,74	2,74	2,74	2,74	2,74	2,74	—	—	—	—	0,63	3,03	3,03	3,03	3,03	3,03	3,03	—	—	—	—	0,75	3,92	4,20	4,20	4,20	4,20	4,20	—	—	—	—	0,88	3,92	4,32	4,32	4,32	4,32	4,32	—	—	—	—	1,00	3,92	4,44	4,44	4,44	4,44	4,44	—	—	—	—	u [mm]	40	3,0	3,0	3,0	3,0	3,0	3,0	—	—	—	—	50	4,5	4,5	4,5	4,5	4,5	4,5	—	—	—	—	60	6,0	6,0	6,0	6,0	6,0	6,0	—	—	—	—	70	7,4	7,4	7,4	7,4	7,4	7,4	—	—	—	—	80	8,8	8,8	8,8	8,8	8,8	8,8	—	—	—	—	90	10,1	10,1	10,1	10,1	10,1	10,1	—	—	—	—	≥ 100	11,5	11,5	11,5	11,5	11,5	11,5	—	—	—	—	$N_{R,k,II}$ [kN]	3,92	4,92	5,91	6,22	6,52	6,52	—	—	—	—	<p>No additional regulations.</p>
t_{N1}, t_{N2}, d, D [mm]		t_{II} [mm]																																																																																																																																																																																																																																																																																															
	4,00	5,00	6,00	7,00	8,00	$\geq 10,0$	—	—	—	—																																																																																																																																																																																																																																																																																							
$V_{R,k}$ [kN]	0,40	0,82	0,82	0,82	0,82	0,82	0,82	—	—	—	—																																																																																																																																																																																																																																																																																						
	0,50	0,93	1,12	1,30	1,30	1,30	1,30	—	—	—	—																																																																																																																																																																																																																																																																																						
	0,55	1,12	1,28	1,44	1,44	1,44	1,44	—	—	—	—																																																																																																																																																																																																																																																																																						
	0,60	1,31	1,45	1,58	1,58	1,58	1,58	—	—	—	—																																																																																																																																																																																																																																																																																						
	0,63	1,42	1,54	1,66	1,66	1,66	1,66	—	—	—	—																																																																																																																																																																																																																																																																																						
	0,75	1,88	1,94	2,00	2,00	2,00	2,00	—	—	—	—																																																																																																																																																																																																																																																																																						
	0,88	2,33	2,57	2,81	2,81	2,81	2,81	—	—	—	—																																																																																																																																																																																																																																																																																						
	1,00	2,74	3,15	3,56	3,56	3,56	3,56	—	—	—	—																																																																																																																																																																																																																																																																																						
$N_{R,k}$ [kN]	0,40	1,65	1,65	1,65	1,65	1,65	1,65	—	—	—	—																																																																																																																																																																																																																																																																																						
	0,50	1,77	1,77	1,77	1,77	1,77	1,77	—	—	—	—																																																																																																																																																																																																																																																																																						
	0,55	2,26	2,26	2,26	2,26	2,26	2,26	—	—	—	—																																																																																																																																																																																																																																																																																						
	0,60	2,74	2,74	2,74	2,74	2,74	2,74	—	—	—	—																																																																																																																																																																																																																																																																																						
	0,63	3,03	3,03	3,03	3,03	3,03	3,03	—	—	—	—																																																																																																																																																																																																																																																																																						
	0,75	3,92	4,20	4,20	4,20	4,20	4,20	—	—	—	—																																																																																																																																																																																																																																																																																						
	0,88	3,92	4,32	4,32	4,32	4,32	4,32	—	—	—	—																																																																																																																																																																																																																																																																																						
	1,00	3,92	4,44	4,44	4,44	4,44	4,44	—	—	—	—																																																																																																																																																																																																																																																																																						
u [mm]	40	3,0	3,0	3,0	3,0	3,0	3,0	—	—	—	—																																																																																																																																																																																																																																																																																						
	50	4,5	4,5	4,5	4,5	4,5	4,5	—	—	—	—																																																																																																																																																																																																																																																																																						
	60	6,0	6,0	6,0	6,0	6,0	6,0	—	—	—	—																																																																																																																																																																																																																																																																																						
	70	7,4	7,4	7,4	7,4	7,4	7,4	—	—	—	—																																																																																																																																																																																																																																																																																						
	80	8,8	8,8	8,8	8,8	8,8	8,8	—	—	—	—																																																																																																																																																																																																																																																																																						
	90	10,1	10,1	10,1	10,1	10,1	10,1	—	—	—	—																																																																																																																																																																																																																																																																																						
≥ 100	11,5	11,5	11,5	11,5	11,5	11,5	—	—	—	—																																																																																																																																																																																																																																																																																							
$N_{R,k,II}$ [kN]	3,92	4,92	5,91	6,22	6,52	6,52	—	—	—	—																																																																																																																																																																																																																																																																																							
<p style="text-align: center;">Self drilling screw</p> <hr/> <p style="text-align: center;">Hilti S-CD 75 GS 5,5 x L Hilti S-CD 75 GSS 5,5 x L with hexagon head and sealing washer Ø22 mm</p> <div style="float: right; text-align: right;">Annex 25</div>																																																																																																																																																																																																																																																																																																	

Annex 15:
ETA-13/0179, Annex 26

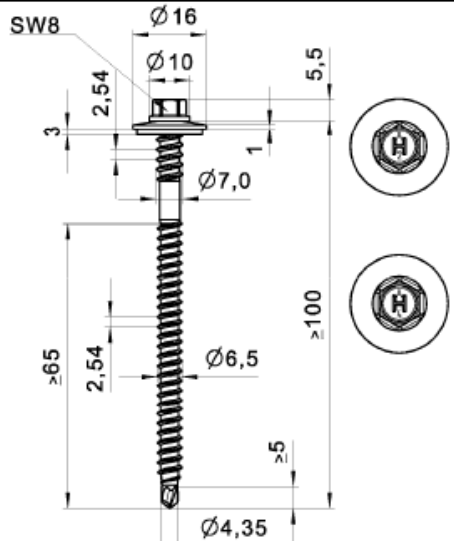

Material:
 Fastener: stainless Steel (1.4301, 1.4401, 1.4571) - EN 10088
 Washer: stainless Steel (1.4301) - EN 10088
 Component I: S280GD, S320GD - EN 10346
 Component II: Structural timber - EN 14081

Drilling capacity: $\Sigma t_i \leq 2,00$ mm

Timber substructures:
 performance determined with

$M_{y,Rk} = 9,741$ Nm
 $f_{ax,k} = 10.769$ N/mm² for $l_{ef} \geq 50.0$ mm

t_{N1}, t_{N2} [mm]	d, D [mm]									
	30	40	50	60	70	80	100	120	≥ 140	
$V_{R,I,k}$ [kN]	0,40	0,62	0,62	0,62	0,62	0,62	0,62	0,62	0,62	0,62
	0,50	0,98	0,98	0,98	0,98	0,98	0,98	0,98	0,98	0,98
	0,55	1,15	1,15	1,15	1,15	1,15	1,15	1,15	1,15	1,15
	0,60	1,37	1,37	1,37	1,37	1,37	1,37	1,37	1,37	1,37
	0,63	1,50	1,50	1,50	1,50	1,50	1,50	1,50	1,50	1,50
	0,75	2,17	2,17	2,17	2,17	2,17	2,17	2,17	2,17	2,17
	0,88	2,17	2,17	2,17	2,17	2,17	2,17	2,17	2,17	2,17
	1,00	2,17	2,17	2,17	2,17	2,17	2,17	2,17	2,17	2,17
$N_{R,I,k}$ [kN]	0,40	—	—	—	—	—	—	—	—	—
	0,50	1,72	1,72	1,72	1,72	1,72	1,72	1,72	1,72	1,72
	0,55	1,96	1,96	1,96	1,96	1,96	1,96	1,96	1,96	1,96
	0,60	2,12	2,12	2,12	2,12	2,12	2,12	2,12	2,12	2,12
	0,63	2,21	2,21	2,21	2,21	2,21	2,21	2,21	2,21	2,21
	0,75	2,73	2,73	2,73	2,73	2,73	2,73	2,73	2,73	2,73
	0,88	3,32	3,32	3,32	3,32	3,32	3,32	3,32	3,32	3,32
	1,00	3,50	3,50	3,50	3,50	3,50	3,50	3,50	3,50	3,50
u [mm]	—	5,0	7,0	9,0	11,0	13,0	18,0	18,0	18,0	
$N_{R,k,II}$ [kN]	3,15	3,15	3,15	3,15	3,15	3,15	3,15	3,15	3,15	

If component t_{N1} resp. t_{N2} is made of S320GD the grey highlighted values may be increased by 8,3%.
 The values listed above in dependence on the screw-in length l_{ef} and the values $N_{R,k,II}$ are valid for $k_{mod} = 0,90$ and timber strength grade C24 ($\rho_a = 350$ kg/m³). For other combinations of k_{mod} and timber strength grades see Annex 3.

Self drilling screw	Annex 26
Hilti S-CDW 51 S 6,5 x L Hilti S-CDW 51 SS 6,5 x L with hexagon head and sealing washer Ø16 mm	

Annex 16:
ETA-13/0179, Annex 27

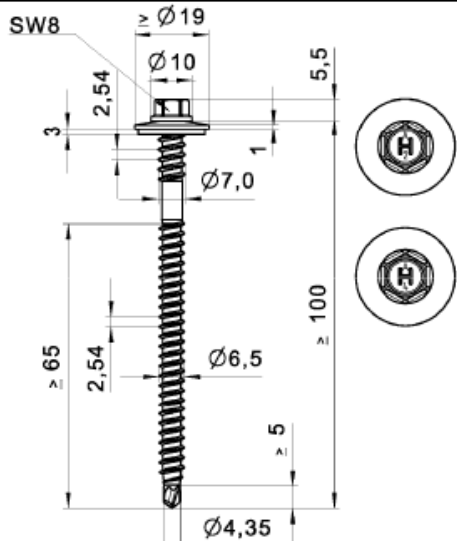

Material:
 Fastener: stainless Steel (1.4301, 1.4401, 1.4571) - EN 10088
 Washer: stainless Steel (1.4301) - EN 10088
 Component I: S280GD, S320GD - EN 10346
 Component II: Structural timber - EN 14081

Drilling capacity: $\Sigma t_i \leq 2,00$ mm

Timber substructures:
 performance determined with

$M_{y,Rk} = 9,741$ Nm
 $f_{ax,k} = 10.769$ N/mm² for $l_{ef} \geq 50,0$ mm

t_{N1}, t_{N2} [mm]	d, D [mm]									
	30	40	50	60	70	80	100	120	≥ 140	
$V_{R,I,k}$ [kN]	0,40	0,62	0,62	0,62	0,62	0,62	0,62	0,62	0,62	0,62
	0,50	0,98	0,98	0,98	0,98	0,98	0,98	0,98	0,98	0,98
	0,55	1,15	1,15	1,15	1,15	1,15	1,15	1,15	1,15	1,15
	0,60	1,37	1,37	1,37	1,37	1,37	1,37	1,37	1,37	1,37
	0,63	1,50	1,50	1,50	1,50	1,50	1,50	1,50	1,50	1,50
	0,75	2,17	2,17	2,17	2,17	2,17	2,17	2,17	2,17	2,17
	0,88	2,17	2,17	2,17	2,17	2,17	2,17	2,17	2,17	2,17
	1,00	2,17	2,17	2,17	2,17	2,17	2,17	2,17	2,17	2,17
$N_{R,I,k}$ [kN]	0,40	—	—	—	—	—	—	—	—	—
	0,50	2,60	2,60	2,60	2,60	2,60	2,60	2,60	2,60	2,60
	0,55	3,10	3,10	3,10	3,10	3,10	3,10	3,10	3,10	3,10
	0,60	3,35	3,35	3,35	3,35	3,35	3,35	3,35	3,35	3,35
	0,63	3,50	3,50	3,50	3,50	3,50	3,50	3,50	3,50	3,50
	0,75	3,50	3,50	3,50	3,50	3,50	3,50	3,50	3,50	3,50
	0,88	3,50	3,50	3,50	3,50	3,50	3,50	3,50	3,50	3,50
	1,00	3,50	3,50	3,50	3,50	3,50	3,50	3,50	3,50	3,50
u [mm]	—	5,0	7,0	9,0	11,0	13,0	18,0	18,0	18,0	
$N_{R,k,II}$ [kN]	3,15	3,15	3,15	3,15	3,15	3,15	3,15	3,15	3,15	

If component t_{N1} resp. t_{N2} is made of S320GD the grey highlighted values may be increased by 8,3%.
 The values listed above in dependence on the screw-in length l_{ef} and the values $N_{R,k,II}$ are valid for $k_{mod} = 0,90$ and timber strength grade C24 ($\rho_a = 350$ kg/m³). For other combinations of k_{mod} and timber strength grades see Annex 3.

Self drilling screw	Annex 27
Hilti S-CDW 61 S 6,5 x L Hilti S-CDW 61 SS 6,5 x L Hilti S-CDW 71 S 6,5 x L Hilti S-CDW 71 SS 6,5 x L with hexagon head and sealing washer $\geq \text{Ø}19$ mm	